



WOODSTOVES.COM
HEAT YOUR HOME. FUEL YOUR LIFE.

PLEASE READ CAREFULLY AND KEEP THIS MANUAL FOR FUTURE REFERENCE

Instruction Manual

POLARIS—VEGA—CENTAURI—POLARIS CLASSIQUE—VEGA CLASSIQUE



YOU CAN CONSULT A PROFESSIONAL INSTALLER, OR ASK FIRE OFFICIALS OR LOCAL AUTHORITY ABOUT RESTRICTION AND INSTALLATION INSPECTION IN YOUR AREA



We recommend that our woodburning hearth products be installed and serviced by professionals who are certified in the U.S. by the National Fireplace Institute® (NFI) as NFI Woodburning Specialists or who are certified in Canada by Wood Energy Technical Training (WETT).



Intertek

Certified to:
ULC S627, UL 1482
ASTM E2780, ASTM E2515
CSA B415.1
2020 U.S. Environmental
Protection Agency's crib wood
emission standard

TABLE OF CONTENTS

INTRODUCTION	3	Stainless steeltubesInstallation	24
LISTING AND CODE APPROVALS	3	How to install tubes	24
Appliance certification	3	OPERATING INSTRUCTIONS	25
Transportable building approved	3	Burn rate category	25
BTU & Efficiency Specifications	3	Category 4 –maximum	25
WARNING	3	Category 3 –Medium	25
RATING PLATE	4	Category 2 –Medium-Minimum	25
APPLIANCE DIMENSION	5	Category 1 –Minimum	25
SPECIFICATIONS	6	Primary and secondary air admission control	25
CLEARANCES TO COMBUSTIBLE MATERIAL	6	Lightning fire	25
INSTALLATION	7	First fire	26
Fire Prevention	7	Keep a fire	26
Smoke and carbon monoxide emissions and monitors	7	Fan Control	27
Floor protection	7	Fuel Selection	27
Floor protection plate minimum dimensions	7	Moisture Meter Information	27
Clearances of the stove until the floor plate protection	7	Efficiency	27
Minimums clearances to combustibile material.....	8	Things not to burn.....	27
Assembly before installation.....	9	Wood storage	27
Leg installation.....	9	Draft	27
Pedestal installation	9	MAINTENANCE	28
Fan and Snap disc box installation	9	Ash Removal	28
Warmer stove Assembly (Centauri)	10	Ash Disposal	28
Firebricks installation	12	Creosote Formation	28
Side firebrick installation	12	Chimney Inspection	28
Back firebrick installation	12	Chimney Sweeping	28
Floor firebricks installation (POLARIS)	12	Door maintenance	29
Floor firebricks installation (VEGA, CENTAURI)	12	Air tight Adjustment	29
Angle firebricks installation	12	Door adjustment (right side)	29
Firebrick installation on the pipes	13	Cleaning up glass	29
Firebox configuration and parts (POLARIS, & POLARIS CLASSIQUE)	14	Uninstalling and installing door	29
Firebox configuration and list of parts (VEGA, CENTAURI)	15	Replacing broken glass	29
GENERAL STOVE INSTALLATION STEPS.....	16	Fiberglass rope replacement.....	29
Location considerations	16	WHAT TO DO IN CASE OF CHIMNEY FIRE	30
General steps of installation	16	ANNEX 1	31
Chimney connector installation	17	Exploded diagram of door	31
Transportable building installation	18	31
Chimney installation, General steps	19	ANNEX 2	31
Inside Masonry Chimney, Vertical Installation	20	Fans electric wiring diagram	32
Outside Vertical Installation	20	Snap disc box parts description	32
Cathedral Vertical Installation.....	21	ANNEX 3	33
Offset Installation	21	Parts that can be replaced	33
Vertical Installation.....	22	ANNEXE 4.....	33
EXTERNAL COMBUSTION AIR SOURCE	23	Pedestal installation	33
Exterior Air Intake pipe	23	J. A. ROBY LIMITED LIFE WARRANTY	36
Installation of Air Intake Pipe	23		
Air Inlet Obstruction	23		
STAINLESSSTEELTUBESREPLACEMENT.....	24		

INTRODUCTION

Savetheseinstructions. This manual describes the operation and installation of J.A. Roby woodstove model: Polaris, Centauri, Vega, Polaris Classique. This appliance responds to 2020 US Environment Protection with sized controlled crib wood. The capacity of this appliance is from 11 527 BTU/h to 21 846 BTU/h. Read the manual carefully before installing your new J.A. Roby stove. A good installation is very important for a safe and effective use of this appliance. If you have doubts about the instruction to install your appliance correctly, we suggest calling a professional installer. A wrong installation may result in a fire, burns and possible death.

Keep these instructions for future reference.

This appliance must be connected to:

- A HT type factory-built chimney approved UL103 or ULC 629 with 6 inches diameter (15.24 cm)
- A code-approved masonry chimney with a flue liner with a 6 inches diameter (15.24cm).

LISTING AND CODE APPROVALS

Appliance certification

The Polaris, Centauri, Vega and Polaris Classique wood stove meets the 2020 U.S. Environmental Protection Agency's crib wood emission standard.

These appliances also meet:

- UL 1482 Standard for Solid-Fuel Type Room Heaters;
- ULC S627 Standard for Space Heaters for Use with Solid Fuels;
- (UM) 84-HUD, Mobile Home approved.

This wood heater has a manufacturer-set minimum low burn rate that must not be altered. It is against federal regulations to alter this setting or otherwise operate this wood heater in a manner inconsistent with operating instructions in this manual.

This wood heater needs regular inspection and repair for proper operation. It is against federal regulations to operate this stove in a manner inconsistent with the instruction in this manual.

Transportable building approved

This appliance is approved for mobile home installations. The structural integrity of the mobile home floor, ceiling, and walls must be maintained. The appliance must be properly grounded to the frame of the mobile home and used only a listed double-wall connector pipe.

The appliance must be fixed on the floor.

Do not install in a sleeping room.

Exterior air inlet is mandatory for mobile home use. All Roof-chimney terminations shall be able to be readily removed at or

below an elevation of 13-1/2 feet (4.1m) above the ground level and reinstalled without the use of special tools or instruction. The chimney assembly shall be provided with a mechanical securement means to secure the chimney to the ceiling support box.

BTU & Efficiency Specifications

- Average efficiency 72.9%
- Particle emission 1.43g/hr
- Minimum Heat Output* 11'527 BTU/hr
- Maximum Heat Output* : 21'846 BTU/hr
- Vent size 6"
- Firebox size 1.55 cubic feet
- Recommended wood length: 18 inches
- Fuel Orientation: side to side.
- Fuel: Seasoned cord wood.

* A range of BTU outputs based on Environment Protection Agency Default Efficiency and the burn rates from the low and high Environment Protection Agency emission tests, using Douglas fir dimensional lumber.

WARNING

If this appliance is in an area where children may be near, it is recommended that you place a decorative barrier in front of the appliance.

HOT WHILE IN OPERATION. KEEP CHILDREN, CLOTHINGS AND FURNITURE AWAY. CONTACT MAY CAUSE SKIN BURN.

N.B: BE WARNED THAT THE LOCAL CODES AND RULES CAN HAVE MORE SPECIFIC REQUIREMENT THAN THIS

PROFESSIONAL CAN CONSULT A INSTALLER OR ASK FIRE OFFICIALS OR LOCAL AUTHORITY ABOUT RESTRICTION AND INSTALLATION INSPECTION IN YOUR AREA.

YOU MIGHT NEED TO OBTAIN A PERMIT FOR INSTALLING CHIMNEY AND STOVE.

DO NOT CONNECT THIS APPLIANCE TO A CHIMNEY FLUE SERVING ANOTHER APPLIANCE.

DO NOT CONNECT TO OR USE IN CONJUNCTION WITH ANY AIR DISTRIBUTION DUCTWORK UNLESS SPECIFICALLY APPROVED FOR SUCH INSTALLATIONS.

THIS APPLIANCE IS BUILT FOR BURNING SEASONED CORDWOOD ONLY. USE OF ANY OTHER TYPE OF FUEL LIKE COAL/ CONSTRUCTION WOOD/ TREATED WOOD/ FLAMABLE LIQUID/ TRASH/ OR ANY FLAMABLE THING CAN OVERFIRE AND DAMAGE THE STOVE.

DO NOT INSTALL IN AN ALCOVE

DO NOT INSTALL IN ANY FIREPLACE

RATING PLATE

FABRIQUÉ AU CANADA
PAR:
MADE IN CANADA BY:



Au cœur de la chaleur
Warmth from the heart of
J.A. Roby Inc.
490 rue de l'Arçon, Québec, Canada,
G2N 2C9

Intertek
W/N XXXXX

W/H-

CERTIFIÉ SELON / CERTIFIED TO:
ULC S627, IUL 1482
ASTM E2780, ASTM E2515
CSA B415.1
Method 2R

NE PAS ENLEVER CETTE ÉTIQUETTE /
DO NOT REMOVE THIS LABEL
MODELS / MODELS:

■ Polaris ■ Sirius ■ Vega ■ Antares ■ Centauri
■ Polaris classique ■ Vega classique ■ Rigel

**POÊLE À COMBUSTIBLES SOLIDES HOMOLOGUÉ.
ÉGALEMENT POUR LES BÂTIMENTS TRANSPORTABLES.
LISTED SOLID FUEL BURNING SPACE HEATER
ALSO SUITABLE FOR TRANSPORTABLE BUILDING.**

AGENCE DE PROTECTION DE L'ENVIRONNEMENT AMÉRICAINE (EPA), CERTIFIÉ
CONFORME AUX NORMES 2020 D'ÉMISSION DE PARTICULES EN UTILISANT DU
BOIS DIMENSIONNÉ. CERTIFIÉ POUR LE CANADA ET LES ÉTATS-UNIS
U.S. ENVIRONMENTAL PROTECTION AGENCY (EPA) CERTIFIED TO COMPLY WITH
2020 PARTICULATE EMISSION STANDARDS USING CRIB WOOD. CERTIFIED IN
BOTH UNITED STATES AND CANADA.

EMISSION RATE / TAUX D'ÉMISSION : 1.43 g/hr—Volume 1.55 cubic feet/pied cube
AVERAGE EFFICIENCY/ EFFICACITÉ MOYENNE : 72.9%
MINIMUM HEAT OUTPUT/ PUISSANCE DE CHAUFFAGE MINIMUM : 11 527 BTU/h
MAXIMUM HEAT OUTPUT / PUISSANCE DE CHAUFFAGE MAXIMUM : 21 846 BTU/h
AVERAGE ELECTRIC CONSUMPTION/ CONSOMMATION ÉLECTRIQUE MOYENNE : 0.03 Watt

Utiliser seulement une cheminée
homologuée HT d'un diamètre intérieur de 6
pouces (152.4 mm) ou une cheminée de
maçonnerie avec un revêtement intérieur
homologuée de 6 pouces. ATTENTION: Les
tuyaux de raccordement au paroi simple
doivent avoir une gaine-chaleur d'une épaisseur
minimale de 29 gages (0.013" / 0.33 mm) fixé
sur le tuyau à une distance de 1 pouce (25.4
mm) du tuyau de raccordement en direction
des murs.

Use only 6 inches (152.4 mm) certified
HT chimney or a code approved masonry
chimney with a 6 inches flue liner. Warning
single wall certified chimney connector must
have a fixed heat-shield with minimal
thickness of 29 gauges (0.0135 inch/ 0.33 mm)
at 1 inches (25.4mm) offset of the chimney
connector facing the wall.



- Ce poêle à bois nécessite une entretien périodique pour fonctionner adéquatement. Consultez le manuel du propriétaire pour plus d'informations. Il est contre les règlements fédéraux des États-Unis de faire fonctionner ce poêle à bois d'une manière incompatible avec les instructions de fonctionnement dans le manuel du propriétaire.
- Installer et utiliser seulement conformément aux instructions du manuel d'installation et d'utilisation du fabricant. Renseignez-vous auprès des responsables locaux de la construction et de la prévention des incendies au sujet des restrictions et inspections des installations dans votre région.
- Cet appareil doit être installé sur les pattes incluses selon les directives du manuel d'installation.
- Cet unité doit être installé sur un protège plancher incombustible de 10mm (3/8") dimensionné selon le dessin ci-haut.
- Toujours s'assurer que l'admission d'air n'est pas obstruée et est ouverte.
- Ne pas surchauffer, si le poêle ou le collet de la cheminée deviennent rouge le poêle surchauffe.
- Ne pas brancher cet appareil sur une cheminée servant à un autre appareil.
- Inspecter et nettoyer la cheminée fréquemment. Sous certaines condition d'opération le créosote peut s'accumuler rapidement.
- Ne pas utiliser de chenets ou de grilles pour lever le feu.
- Préparer le feu directement sur l'âtre.
- Remplacer la vitre par un verre opérationnel de 4mm d'épaisseur.
- Pour une utilisation avec un bois de chauffage seulement - NE PAS BRÛLER AUCUN AUTRE COMBUSTIBLE.
- Brûler avec la porte fermée.
- Ouvrir l'admission d'air avant d'ouvrir la porte
- Ne pas obstruer l'espace sous le poêle
- Pour passer la cheminée à travers un mur ou un plafond combustible, le lire le manuel d'installation et le code du bâtiment local.
- Se référer au répertoire des produits homologués (<https://bpdirectory.intertek.com>) pour plus d'information.
- ATTENTION- Les pièces mobiles peuvent causer des blessures. Ne pas opérer l'appareil avec le ventilateur retiré, si équipé.
- ATTENTION- Pièces chaudes. Ne pas opérer l'appareil avec le ventilateur retiré, si équipé.
- DANGER- Risque de chocs électriques. Débrancher l'alimentation avant de réparer l'unité
- Ventilateur J.A. Roby : 2 ventilateurs de 75 cfm/no pièce : VENT) (120V/ 60 Hz/ 0.8 Amp)
- Voir les instructions d'installation des ventilateur à l'intérieur de la boîte et s'assurer que les ventilateurs sont débranchés avant l'installation

- This wood heater needs periodic inspection and repair for proper operation. Consult the owner's manual for further information. It is against federal regulations to operate this wood heater in a manner inconsistent with the operating instructions in the owner's manual.
- Install and use only in accordance with manufacturer's Installation and Operating Instructions. Contact local building or fire officials about restrictions and installation inspection in your area.
- This appliance must be installed with the legs provided, attached as shown in the installation manual.
- This Appliance Must Be Placed on a 10 mm (3/8") non-combustible floor protection like schematic dimension above.
- Always be sure that the external air inlet are not obstructed and open.
- Do Not Overfire - If heater or chimney connector glows, you are overfiring.
- Do Not Connect This Unit to a Chimney Serving Another Appliance.
- Inspect And Clean Chimney Frequently - Under Certain Conditions Of Use, Creosote Buildup May Occur Rapidly.
- Do Not Use Grate Or Elevate Firebuild Wood.
- Fire Directly On Hearth.
- Replace Glass Only With Ceramic Glass 4mm Thick.
- For Use With Solid Wood Fuel Only - DO NOT BURN ANY OTHER FUEL.
- Burn With The Door Closed.
- Open damper before opening the door.
- Do not obstructing space under heater
- To pass chimney or chimney connector through combustible wall or ceiling, see owner manual and local building code.
- Refer to intertek's directory of building products (<https://bpdirectory.intertek.com>) for detailed information.
- CAUTION- Moving parts may cause injury. Do not operate unit with blower removed, if equipped.
- CAUTION- Hot parts. Do not operate unit with blower removed, if equipped.
- DANGER- Risk of electric shock. Disconnect power before servicing unit.
- J.A. Roby Blowers : 2 x 75 cfm (part number : VENT) (120V/ 60Hz/0.8 Amp)
- See blower installation inside the box and be sure the blower is disconnect from power before installation.

CAUTION!
HOT WHILE IN OPERATION. DO NOT TOUCH. KEEP
CHILDREN, CLOTHING AND FURNITURE AWAY.
CONTACT MAY CAUSE SKIN BURNS. SEE
NAME-PLATE AND INSTRUCTION.

ATTENTION!
CHAUD LORSQU'EN FONCTION, NE PAS TOUCHER, GARDER LOIN
DES ENFANTS, DES TISSUS ET DES MEUBLES. LE CONTACT PEUT
CAUSER DES BRÛLURES À LA PEAU. VOIR LA PLAQUE
SIGNALÉTIQUE ET LES INSTRUCTIONS.

APPLIANCE DIMENSION

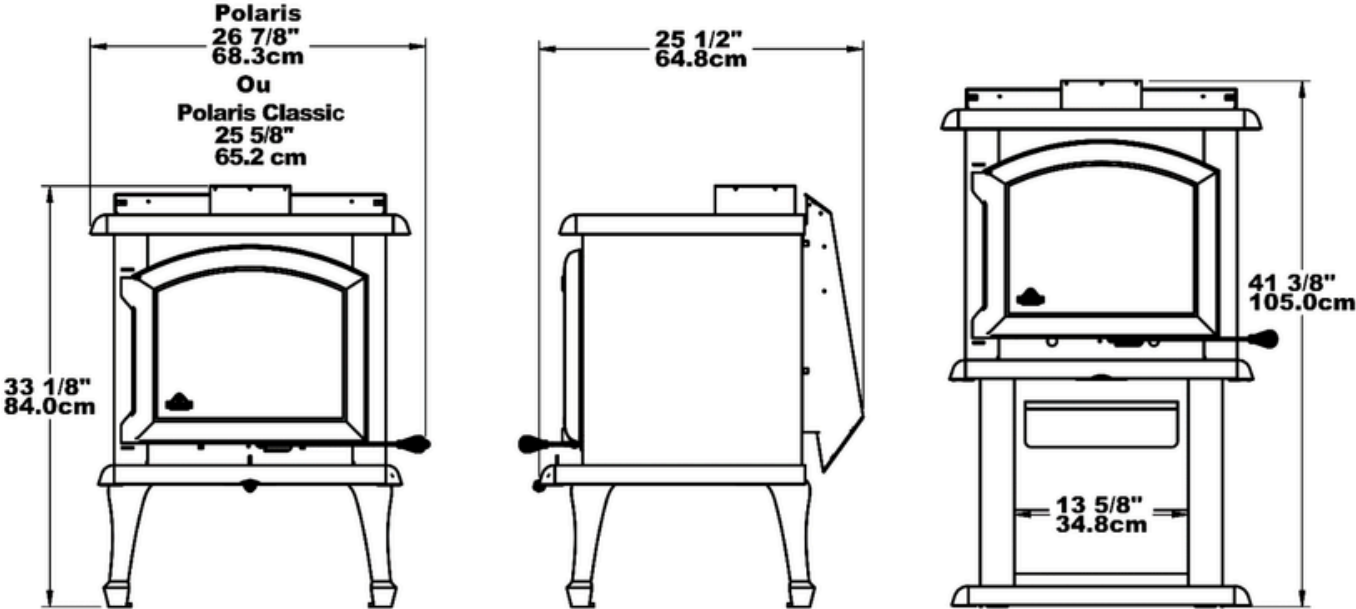

SPECIFICATIONS

Option	Polaris, Sirius,	Vega, Antares	Rigel, Centauri	Polaris Classique	Vega Classique
Combustible	Wood	Wood	Wood	Wood	Wood
Recommended surface area	500 > 1800 ft ²	500 > 1800 ft ²	500 > 1800 ft ²	500 > 1800 ft ²	500 > 1800 ft ²
Cooking lids/Cast iron corners	Yes	Yes	Yes	No	No
Capacity	21 846 BTU/h	21 846 BTU/h	21 846 BTU/h	21 846 BTU/h	21 846 BTU/h
Flue pipe diameter	6 in (15.4 cm)	6 in (15.4 cm)	6 in (15.4 cm)	6 in (15.4 cm)	6 in (15.4 cm)
Minimal chimney height	12 ft (366 cm)	12 ft (366 cm)	12 ft (366 cm)	12 ft (366 cm)	12 ft (366 cm)
Exterior Height	33 in (83.8 cm)	41.3 in (104.1 cm)	54 1/8 in (137.5 cm)	33 in (83.8 cm)	41.3 in (104.1 cm)
Exterior Width	26 7/8 in (68.3 cm)	26 7/8 in (68.3 cm)	26 7/8 in (68.3 cm)	26 7/8 in (68.3 cm)	26 7/8 in (68.3 cm)
Exterior Depth	25 1/2 in (64.8 cm)	25 1/2 in (64.8 cm)	25 1/2 in (64.8 cm)	25 1/2 in (64.8 cm)	25 1/2 in (64.8 cm)
Door Opening	15 1/2 in x 9 in 39.4 cm x 22.9 cm	15 1/2 in x 9 in 39.4 cm x 22.9 cm	15 1/2 in x 9 in 39.4 cm x 22.9 cm	15 1/2 in x 9 in 39.4 cm x 22.9 cm	15 1/2 in x 9 in 39.4 cm x 22.9 cm
Interior Height	10 5/16 in (27.6 cm)	10 5/16 in (27.6 cm)	10 5/16 in (27.6 cm)	10 5/16 in (27.6 cm)	10 5/16 in (27.6 cm)
Interior Width	18 1/4 in (46.7 cm)	18 1/4 in (46.7 cm)	18 1/4 in (46.7 cm)	18 1/4 in (46.7 cm)	18 1/4 in (46.7 cm)
Interior Depth	14 5/16 in (40 cm)	14 5/16 in (40 cm)	14 5/16 in (40 cm)	14 5/16 in (40 cm)	14 5/16 in (40 cm)
Maximum log length	18 in (45.7 cm)	18 in (45.7 cm)	18 in (45.7 cm)	18 in (45.7 cm)	18 in (45.7 cm)
Average combustion time	3 to 8 hours	3 à 8 hours	3 à 8 hours	3 to 8 hours	3 à 8 hours
Weight	266 lbs (120.7 kg)	297 lbs (134.7 kg)	320 lbs (145.1 kg)	266 lbs (120.7 kg)	297 lbs (134.7 kg)

CLEARANCES TO COMBUSTIBLE MATERIAL

	All models
Back	10 in (25.4 cm)
Side	20 in (50.8 cm)
Front	48 in (121.9 cm)
Minimum Ceiling Height	84 in (213.4 cm)
Back of Flue Collar	11 in (27.9 cm)
Side of Flue Collar	29.4 in (74.6 cm)
In corner installation	8 inches (20.3 cm)

INSTALLATION

If this room heater is not properly installed, a house fire may result. To reduce the risk of fire, follow the installation instructions. Contact local building or fire officials about restrictions and installation inspection requirements in your area. **WARNING ALWAYS USE J.A. ROBY PARTS** on your appliance. Using other differences parts can damage the appliance and cause injury.

Fire Prevention Smoke and carbon monoxide emissions and monitors

To provide reasonable fire prevention, the following should be given serious consideration:

1. At least one smoke detector on each floor of your home should be installed to ensure your safety. They should be located away from the heating appliance and close to the sleeping areas. Follow the smoke detector manufacturer's placement and installation instructions and be sure to maintain regularly.
2. A conveniently located Class A fire extinguisher to contend with small fires resulting from burning embers.
3. A CO detector should be installed in the room with the appliance.
4. A practiced evacuation plan, consisting of at least two escape routes.
5. A plan to deal with a chimney fire as follows:
 - a. In the event of a chimney fire:
 - b. Evacuate the house immediately
 - c. Notify fire department.

The average of the CO emission (carbon monoxide) is 1.34 g/min. To maintain this rate, it's recommended to operate the appliance in low or medium burn rate.

The hazards with some fuels (e.g., charcoal) and the possibilities of generating carbon monoxide and the hazards from carbon monoxides.

The hazards with some fuels (e.g., charcoal) and the possibilities of generating carbon monoxide and the hazards from carbon monoxides.

When the smoke detector is activated is mean that the smoke spill out of the appliance. Verify the door is close and the draft in chimney is good.

Floor protection

Your stove must be installed on a non-combustible material plate to protect the floor and avoid fire caused by:

- Projections of sparks when opening door or loading logs
- The heat radiation from stove runaway which might cause an auto-ignition to the floor and the coating
- Flow of creosote when there is a fire chimney.

The coating used for the protection must be non-combustible and approved according to standard UL1618 for USA or approved to the locals codes (Example: cement, brick, ceramic tiles, etc.)

HORIZONTAL VENTING MANDATORY Non-combustible floor protections must extend beneath the flue pipe when installed with horizontal venting and it should extend 2 inches (51 mm) beyond each side of the pipe.

You can extend the protection plate while respecting the clearances of each side of stove.
Floor protection plate minimum dimensions

The following dimensions are the minimums values and it can be higher.

Canada:

- 41.2 inches (104.8 cm)
- 47 inches (119.4 cm)
- 3/8 inch thick (1 cm)

United States:

- 41.2 inches (104.8 cm)
- 45 inches (114.3 cm)
- 3/8 inch thick (1 cm)

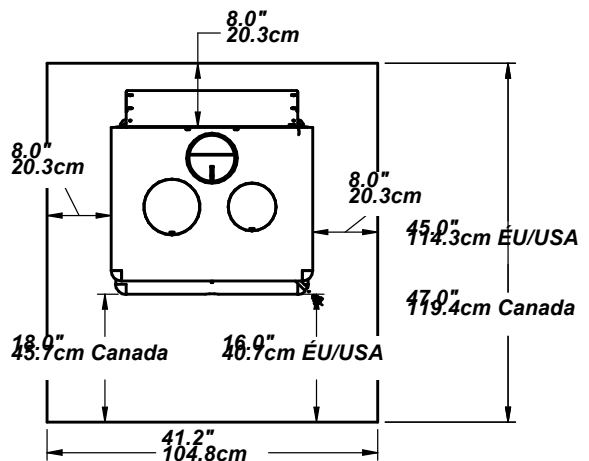

Clearances of the stove until the floor plate protection

The following dimensions are the minimums values and it can be higher.

Canada:

- 8 in (20.3 cm) behind
- 8 in (20.3 cm) beside
- 18 in (45.7 cm) in front of the door opening.

United States:

- 8 in (20.3 cm) behind
- 8 in (20.3 cm) beside
- 16 in (40.64 cm) in front of the door opening.

Minimums clearances to combustibile material

With these reduced clearances, this appliance take a minimum space to be installed. Whether in the living room or the dining room, this appliance will complete your decorate by his originality and heating. It requires a minimum clearance of 10 inches (25.4 cm) to the back (**for a smoke simple pipe with a heat shield**) and a 20 inches (50.8 cm) lateral **MINIMUM** clearance.

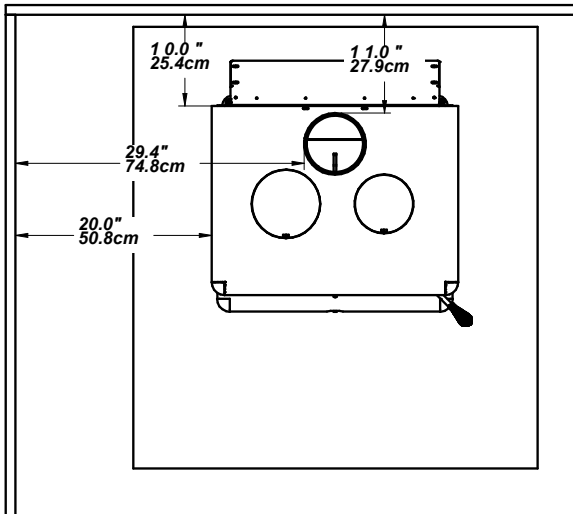

- In the case with a smoke simple pipe without heat shield, you must install the stove that the smoke pipe is to 18 inches (47.5 cm) of all combustibile material therefore the **MINIMUM** clearance at the back of the stove will be 12½ inches (41.3cm).

- For a 45° corner or other corner installation, the minimum clearance between the stove and combustibile material must be 8 inches.

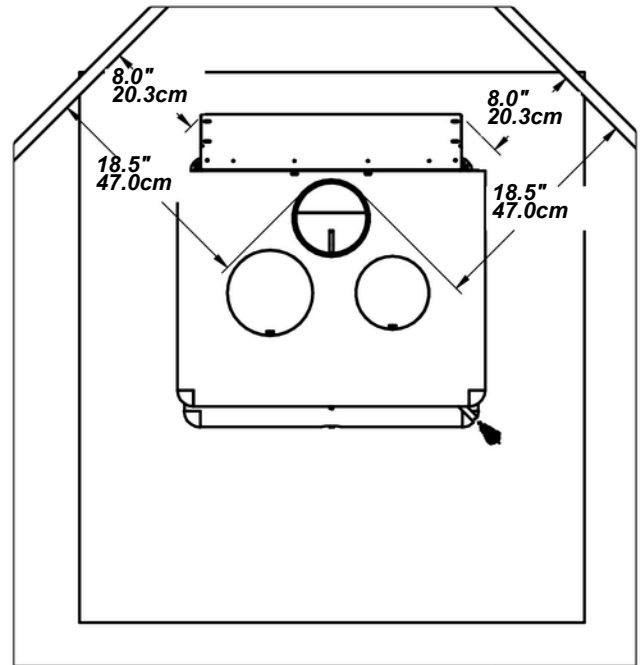

To know how to reduce that dimension, you have to contact your local authority for installing heat shield on a wall. The Installation with reduced clearances must comply with standard NFPA211 or CAN/CSA-B365.

TO REDUCE THESE DIMENSIONS, YOU NEED TO CONTACT YOUR LOCAL AUTHORITY BEFORE INSTALLING A HEAT SHIELD ON A WALL. THE INSTALLATION MUST COMPLY WITH STANDARD NFPA211 OR CAN/CSA-B365 FOR REDUCED CLEARANCES

Assembly before installation

Depending on the stove model, legs may not have been installed at the plant for shipping purposes. You may be required to install at reception of the stove.

Leg installation

- 1) Remove legs and bricks from combustion room.
- 2) Unscrew the stove from the skids.
- 3) Put the stove on its back and be careful to protect the paint.

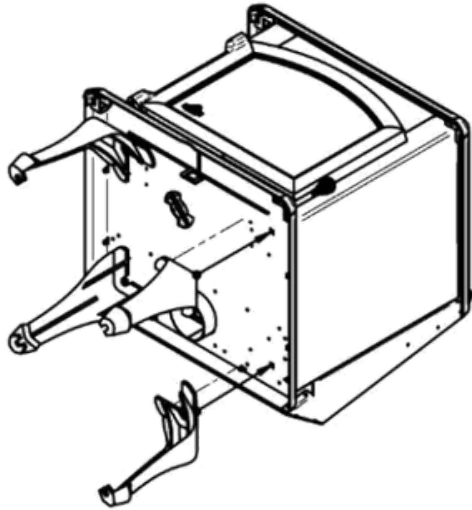

- 4) Loosen the nut (#2) at the corners without removing completely.
- 5) Install the legs (#1) as illustrated and secure it with nut and washer (#2, #3) (Attention: Make sure the legs are in place, correctly positioned and in position with the bottom of the stove.)

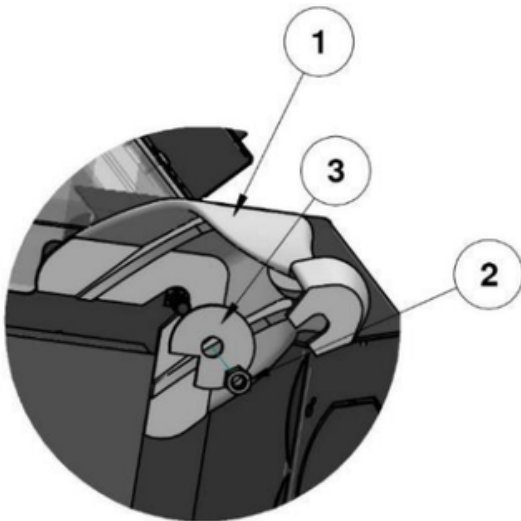

Pedestal installation

See appendix 4.

Fan and Snap disc box installation

The 150 CFM blower kit "VENT" is a Ready to Use option. Depending on the stove model, the blower kit can be included or purchased as an option.

This blower assembly is intended for use only with your J. A. ROBY room heater. Installation instructions for your optional blower kit "VENT" is also included within the blower box.

WARNING: The blower assembly must be disconnected from any source of electrical supply before attempting the installation.

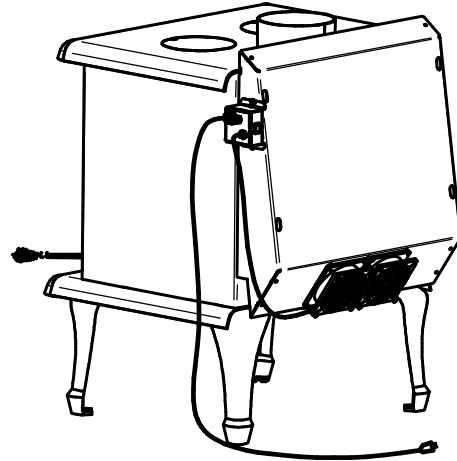

- 1) Screw the fans on the ventilation box as illustrated. Make sure to place the cables as shown.

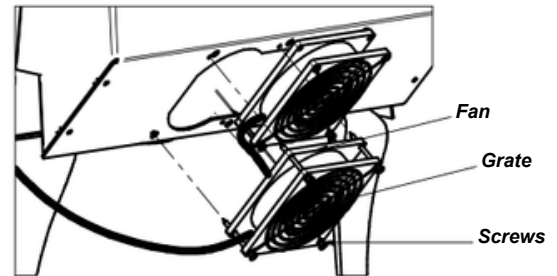

- 2) Screw snap disc box into the holes on the back side near the vent box.

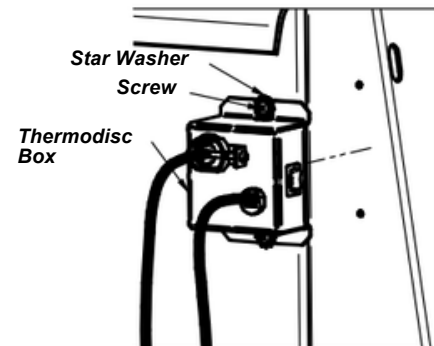

WARNING: NEVER POSITION POWER CORD UNDER OR IN FRONT OF THE APPLIANCE.

Warmer stove Assembly (CENTAURI)

Now, you need to know which type of smoke pipe: smoke simple pipe or smoke double pipe.

For the smoke simple pipe, it's not necessary to remove the pre-cut metal part.

For the smoke double pipe, you must remove the pre-cut metal part on the top, inside and in front of the warmer. See pictures below.

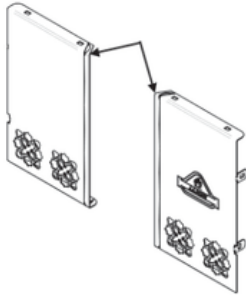

- 1) Put the packaging product on the ground and put the back on it to protect the painted part.

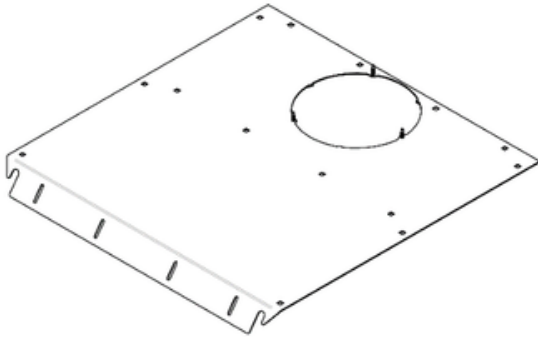

- 2) Fix the left side.

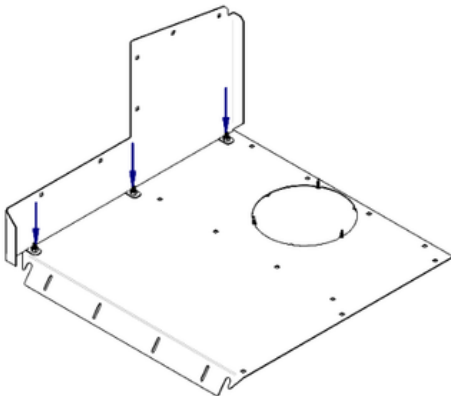

- 3) Fix the right side.

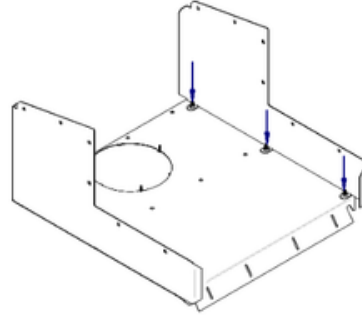

- 4) Fix the front (with the door) with the two sides and the back. Keep the horizontal holes empty for the chrome decoration.

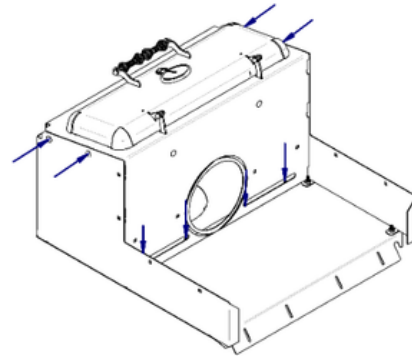

- 5) Insert the chrome decoration in the hole and fix it with carriage bolt and nut (2 bolts each).

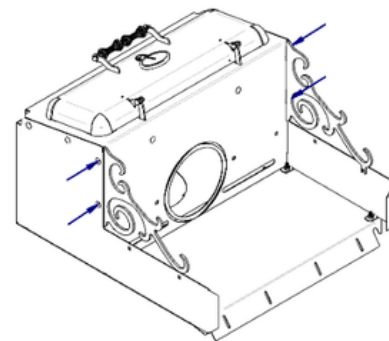

6) Fix the top with the back and with the front as well.

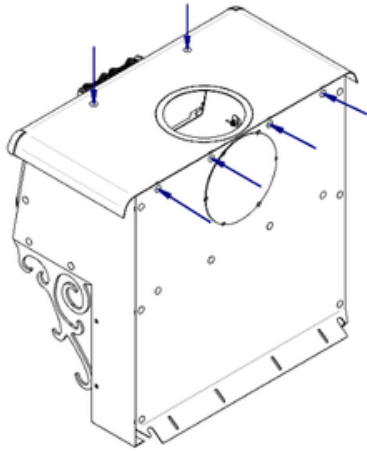

9) Put and fix the warmer with the 4 holes at the back of the wood stove

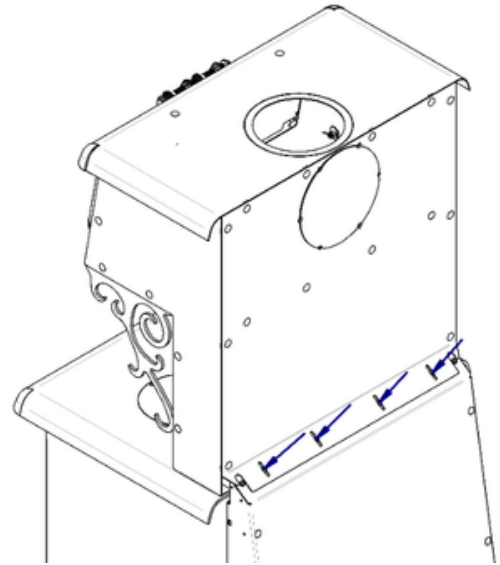

7) Fix the left decorative panel side and install the left chrome decoration.

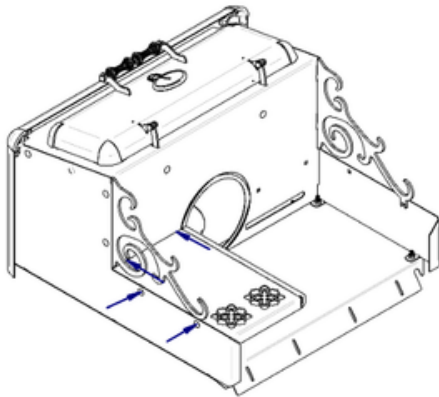

8) Fix the right decorative panel side and finish installing the right chrome decoration.

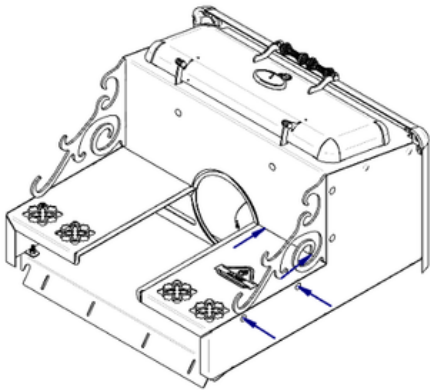

Firebricks installation

Side firebrick installation

Put 4 bricks "A" as shown.

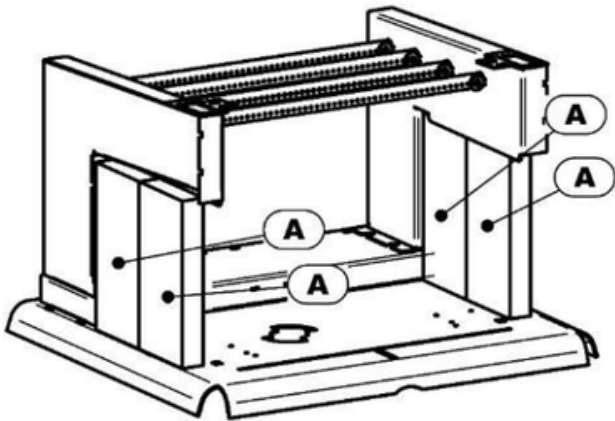

Floor firebricks installation (POLARIS)

Put 2 Bricks «O» near the walls and 2 bricks «P» in the center.

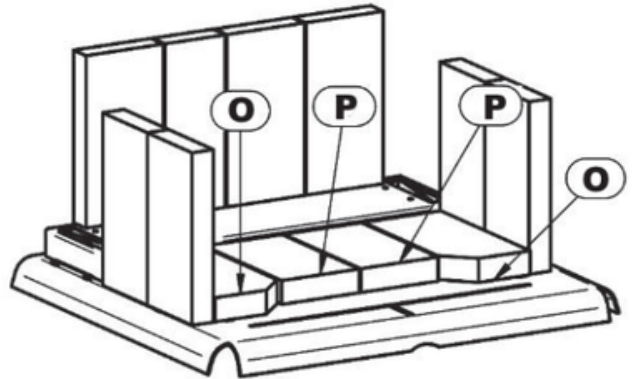

Floor firebricks installation (VEGA & CENTAURI)

Put 2 Bricks «O» near the walls and 1 bricks «P» in the center.
Put 1 brick «Q» behind the ash plug hole

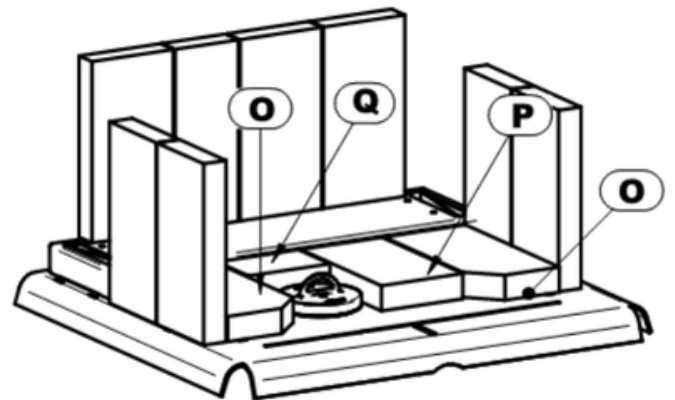

Back firebrick installation

Put 3 bricks «A» and 1 brick «M» on the back wall.

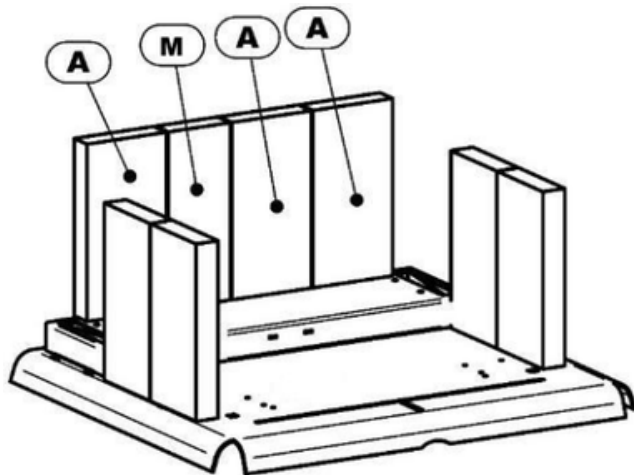

Angle firebricks installation

Put «M» and «N» brick on the top of the back bricks and tangent to the last tube.

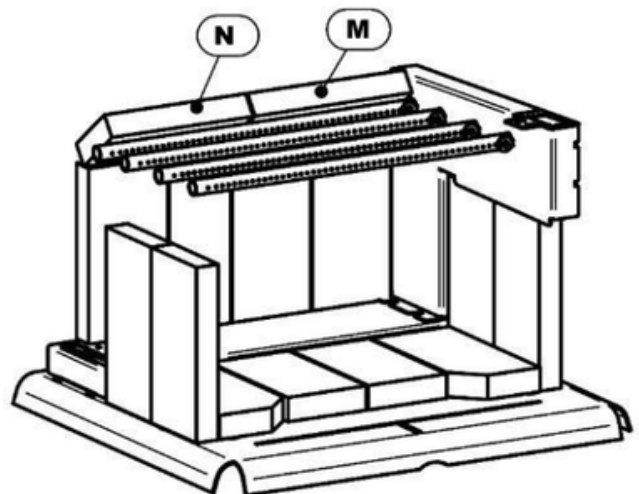

Firebrick installation on the pipes

The firebricks must be put on the 3 pipes from the front of combustion chamber. Bricks keep the maximum heat inside the combustion chamber and help the air from the tube burn the most of the gas from wood which wouldn't be burnt in any other manner.

The rockwool above the brick prevents leakage between the bricks and keep a maximum heat inside combustion chamber. It must cover up all the bricks and the air corridors of both sides.

IMPORTANT: The rockwool must not obstruct the smoke exit way. Check from the hole in the flue collar and make sure that is in the good position. Place two half-round steel parts on the rockwool as illustrated.

- 1) Put 3 « A » bricks and 1 « M » brick vertically over the first three top pipes and push them against the back angle brick. Be sure to eliminate any space between the back bricks and the bricks you install as shown.

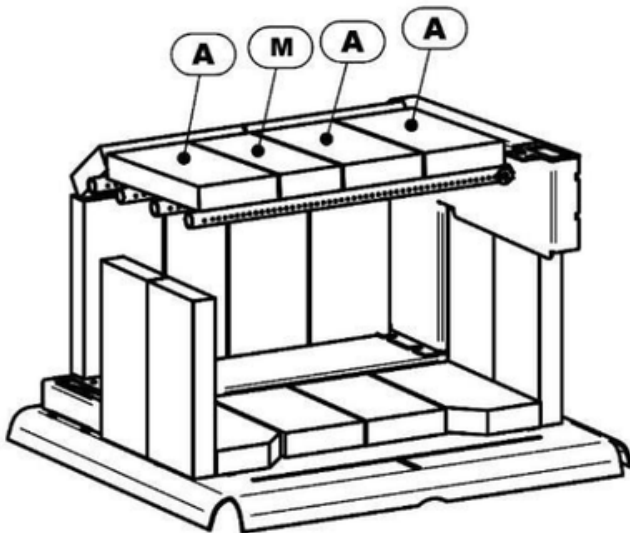

- 2) Put the rockwool over the bricks and check from the hole in the flue collar that the passage of smoke is not obstructed. There must be 1 inch (2.54 cm) or more between the rockwool and the deflector.
- 3) Put two half-round steel disks over the rockwool near the rear deflector already in place. Be sure to put it under the rear deflector to maximise the clearance between rockwool and the rear deflector. Make sure the rockwool is not obstructing the space by looking from the hole in the flue collar.

WARNING: Obstructing smoke exit way under deflector can force fume to exit by the door when open it and the stove must not work properly.

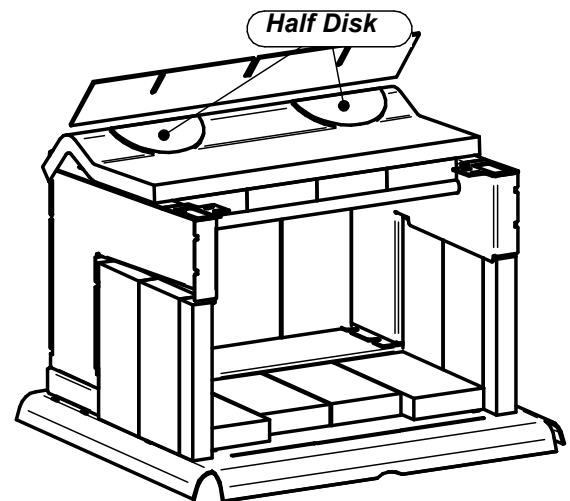

Firebox configuration and parts (POLARIS & POLARIS CLASSIQUE)

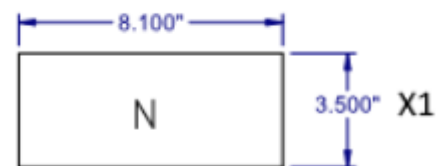
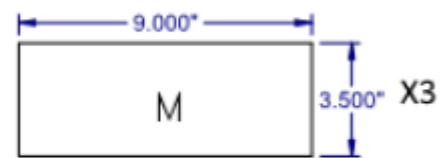
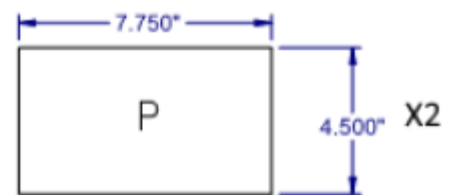
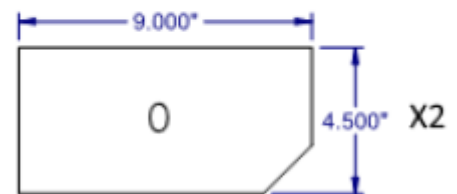
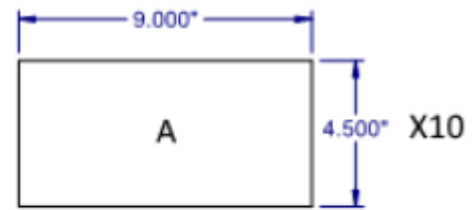
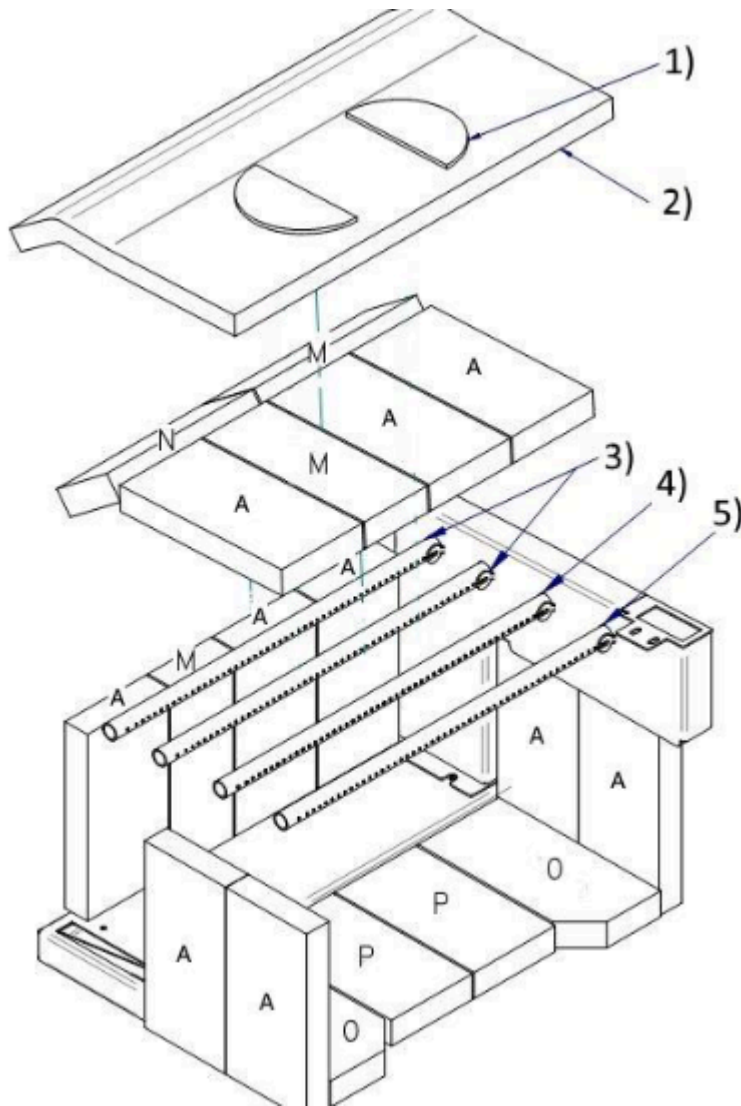

- 1) 2 half-disk metal steel plates
- 2) 1 rock wool insulating blanket
- 3) 2 $\text{Ø } \frac{3}{4}'' \times 18 \frac{3}{16}''$ pipe with holes on a single side
- 4) 1 $\text{Ø } \frac{3}{4}'' \times 18 \frac{3}{16}''$ pipe with bigger holes on a single side
- 5) 1 $\text{Ø } \frac{3}{4}'' \times 18 \frac{3}{16}''$ pipe with holes on both sides

Firebox configuration and list of parts (VEGA, CENTAURI)

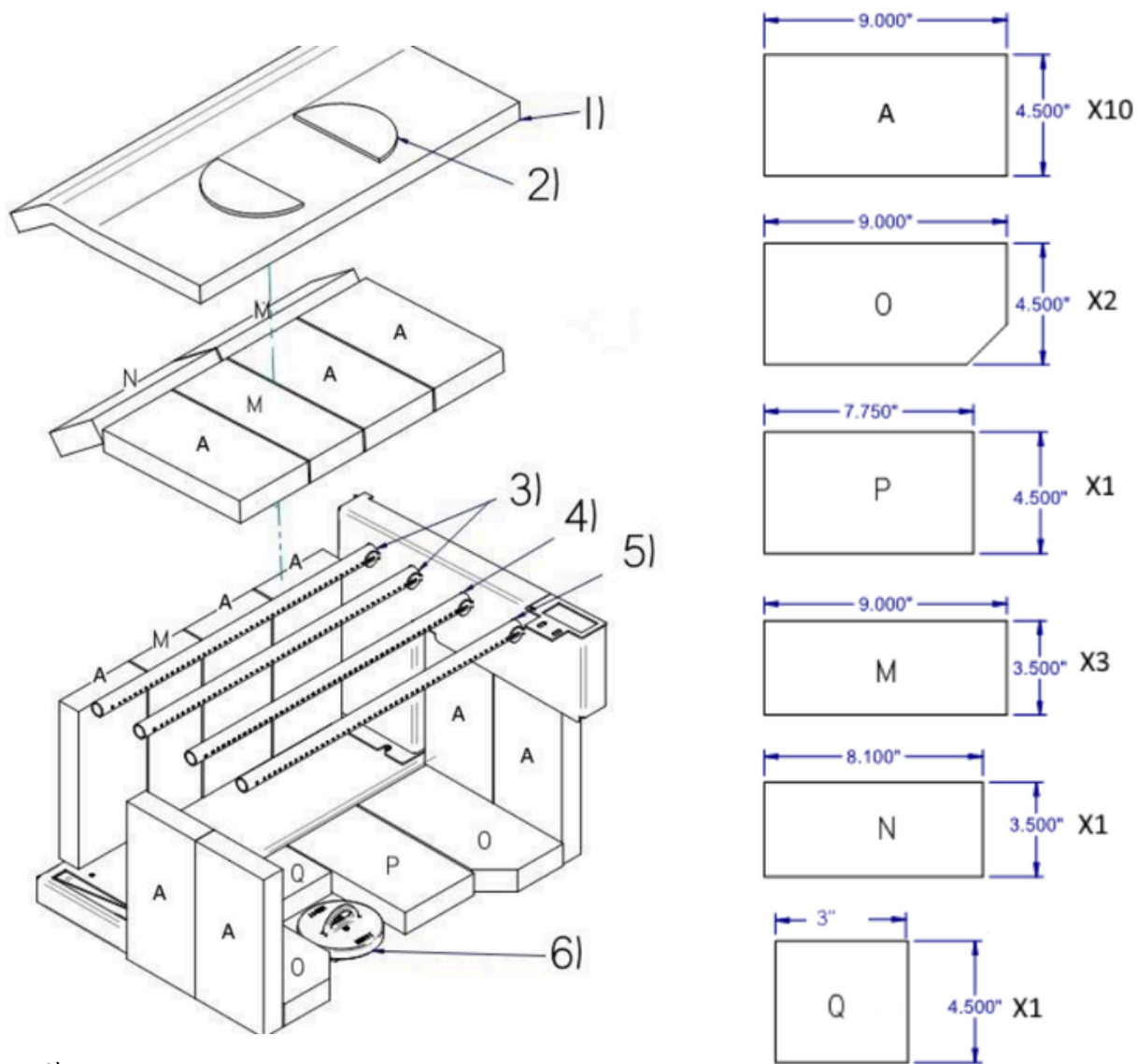

- 1) 2 half-disk metal steel plates
- 2) 1 rock wool insulating blanket
- 3) 2 $\varnothing \frac{3}{4}'' \times 18 \frac{3}{16}''$ pipe with holes on a single side
- 4) 1 $\varnothing \frac{3}{4}'' \times 18 \frac{3}{16}''$ pipe with bigger holes on a single side
- 5) 1 $\varnothing \frac{3}{4}'' \times 18 \frac{3}{16}''$ pipe with holes on both sides
- 6) 1 Ash plug

GENERAL STOVE INSTALLATION STEPS

Location considerations

We recommend installation of this appliance by a certified installer.

Consideration must be given to:

- Safety
- Traffic flow
- Convenience
- Chimney and chimney connector required
- Draft.

Drawing your installation plan on paper is a good way to avoid mistake.

Write on the plan:

- Exact dimensions for clearances to combustible material
- Exact dimensions of the floor protection
- Measurements of the chimney location. (If it not already installed. Be sure to have all clearances recommended by the factory-built chimney manufacturer to pass through the ceiling and roof).

We recommend that a qualified building inspector and your insurance company representative review your plan before and after installation.

General steps of installation

- 1) Read the entire installation manual before installing and using your stove.
- 2) Choose a spot where to install your stove. Read section about floor protection dimension, localisation of stove over the floor protection plate and combustible material clearance. Once you have decided where to install the stove, mark the roof at the center of chimney.
 - o To be sure that the vertical center of the chimney, use a plumb line and mark the center on the floor.
- 3) Check if it possible to pass chimney without damaging the structural integrity of your house. If so, you have to move the location of the stove while keeping the minimum clearance or more to be sure. If you can't move the stove and have to cut through a beam, make sure to keep the structural integrity of your house by following state of the art and National building code.
 - o We recommend installation of this appliance by a certified installer.

Only use certified parts, fail to comply may augment the risk of fire, injuries or even death. If you have doubt, please contact a professional installer.

Note: This appliance has to be connected to 6 inches (15.24 cm) factory build chimney HT UL 103 or CAN/ULC S629 compliant or a 6 inches (15.24 cm) masonry chimney with a homologated sleeve inside. Do not install the chimney directly at the outlet of the appliance. A chimney connector (flue pipe) is required unless the appliance is specifically approved for that type of installation.

- 4) Install the chimney following the manufacturer instruction.
- 5) Put the stove directly on the floor aligned vertically with the center of chimney and trace the side of the stove on the floor and remove it.
- 6) Trace the dimension of protection plate on the floor. There must be 8 inch (20.3cm) clearance from the side and the back of the stove. From the front of the door opening, there must be a clearance of 16 inches (40.6 cm) in US and 18 inches (45cm) in Canada. If the space heater meeting the requirement of CAN/ULC-S627 is suitable for installation on a combustible floor and do not require radiant floor protection.
- 7) Install the floor protection plate inside the mark (It must be non-combustible).
- 8) Put the stove on the protection floor plate and respect the offset clearances set at step 6. Be sure to center the stove under the chimney. We recommend to fix the stove to the floor with bolt in the slot made for this purpose in the legs. In a mobile home, it is obliged to fix the stove.
- 9) If you have an outside air inlet, you must use 4 inches (10.16cm) flexible aluminum pipe. The pipe must be sealed with thermal resistant sealant and it has an air intake with grate approved for this purpose.
- 10) Install the chimney connector on the stove. The pipe must be fixed with at least 3 screws on the stove collar, each chimney connector and the chimney collar.

Note: The single wall or double wall chimney connector must be 6 inches diameter and have a minimum thickness of 24 gauge (0.025 inches 0.64 mm). Do not use galvanised steel chimney connector.

Chimney connector installation

Use only approved chimneys, the same size as the stove collar, 6 inches in this case. The chimneys used must be tested according to CAN/ULC S629 M87 in Canada and to UL 103 (Type HT chimneys in Standard for Chimneys, Factory-Built, Residential Type and Building Heating Appliance) in USA. The stove can be installed with a masonry chimney according to ULC S635, ULC S640 and UL 1777. The masonry chimney must be equipped with a stainless-steel sleeve and meet the standards for masonry chimney with inner sleeve.

Double wall chimney connector

The stove was designed and tested with a **single wall chimney connector with heat shield**. 1.5 inch (15.2 cm) double wall certified chimney connector.

ATTENTION:

For the clearance between combustible materials and double wall chimney connector, see manufacturer manual.

1. Single wall chimney connector

For the single wall chimney connector, it must be 6 inches diameter and minimum thickness of 22 gauge (0.029 inches (0.85 mm)). **Install a metal heatshield, 1 inch (25.4mm) offset for the single wall section and elbow. ATTENTION:**

- *If heat shield is not present, you must move away the stove to keep 18 inches (45.7 cm) clearance between combustibles materials and the chimney connector.*
- *Any horizontal section must have a 1/4 inches (6.35 mm) by feet (30 cm) slope toward the chimney collar.*
- *Clearance between roof and horizontal single wall chimney connector must be 18 inch (45.7 cm) or more.*
- *Clearance between roof and horizontal double wall chimney connector, follow chimney connector manufacturer indication.*

ALL SECTION AND ELBOW MUST BE CLEAN AND IN GOOD CONDITION AND MUST BE APPROVED FOR A CORDWOOD FUEL.

Chimney connector assembly installation

1. Make a summary installation of all sections and elbows (if necessary) to ensure that you meet the clearances and inclinations of the horizontal sections and verify if you have all the necessary parts for the final installation.

- o For direct vertical installation, you will need:
 - 1 vertical section of 24 inches or more
 - 1 adequate length of telescopic chimney connector section allowing you to connect the last chimney connector to the chimney collar.

Note: *Additional section can be used for higher roof.*

- o For horizontal run installation you will need:
 - 1 adequate length of vertical section
 - 1 x 90° elbow or 2 x 45° elbow.
 - 1 x adequate length of telescopic chimney connector section.

Note: *For better draft performance, two 45 degrees elbow are preferable, with or without straight section in between.*

2. Disassemble the whole thing and restart screwing the pieces from the stove to the roof chimney collar
3. Insert entirely the rolled end into the stove collar and screwing it with a minimum of 3 screws.

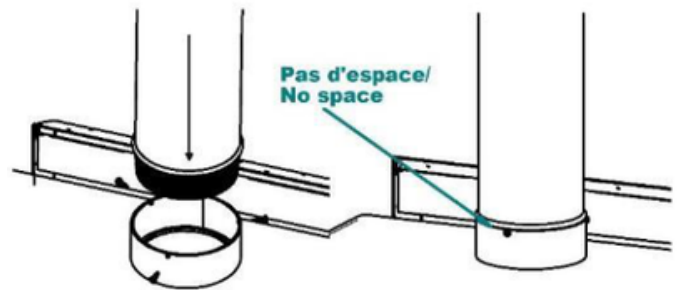

4. Install all the next section up to the roof chimney support and screw every chimney connector parts with 3 screws
WARNING: It is mandatory to screw the pipe to the stove collar and also at each joints with a minimum of 3 screws.
5. Install all the next section and screw it to the chimney collar.

DO NOT CONNECT CONECT THIS UNIT TO A CHIMNEY FLUE SERVING ANOTHER APPLIANCE.

CONNECTOR PIPES SHOULD NEVER PASS THROUGH THE CEILING, THROUGH A WALL, IN A CLOSET, IN AN ATTIC OR OTHER ENCLOSED AREA THAT COULD CAUSE HEAT BUILDUP. IF YOU NEED TO PASS THROUGH COMBUSTIBLE MATERIAL, MAKE SURE THAT YOUR INSTALLATION COMPLIES WITH CAN/CSA-B365.

Transportable building installation

DANGER: DONOT INSTALL IN BEDROOM.

WARNING: THE STRUCTURAL INTEGRITY OF THE TRANSPORTABLE BUILDING FLOOR, WALL, AND CEILING/ROOF MUST BE MAINTAINED.

VAPOR BARRIER EFFICACY MUST BE KEPT IN GOOD CONDITION.

1) Do the General stove installation from steps 1 to 11.

2) The following requirements are MANDATORY for installation in a transportable building.

a. The stove must be fixed on the floor of mobile home with bolt and nuts.

b. The exterior air intake must be installed.

c. The stove must be electrically grounded to chassis of the mobile home. In USA, electrical grounding to the certified terminals with 8 gauge wire and using star washer are mandatory.

d. All of the following equipment must be certified and approved for mobile home installation.

- Double wall chimney connector
- The chimney system
- The roof flashing
- The Storm collar
- Cap with spark arrester
- Firewall
- Chimney ceiling support

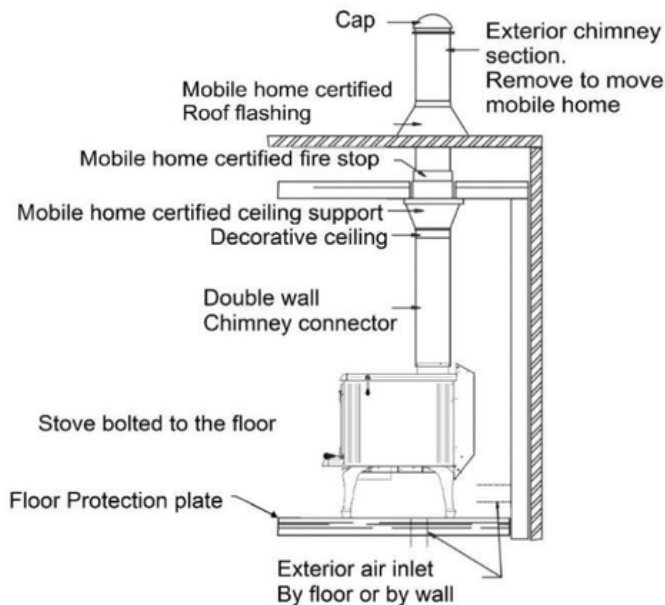

Decorative collar.

e. If the chimney is exposed outside from a wall and placed lower than 7 feet (213 cm) above the ground level where the mobile home is situated, a shield must be installed around the chimney from the bottom to 7 feet (213 cm) high. If openings are made into the shield, they must be less than 3/4 inch (2 cm) wide and keep the distance of 4 inches (10,2 cm) or more in order to avoid contact with chimney.

f. The chimney must exceed at least 3 feet (91,4 cm) from the highest point of opening made in the roof and exceed also 2 feet from the highest point of the roof which is 10 feet away from the chimney.

g. Be sure to correctly seal the flashing of the roof, the firewall and the exterior air inlet with sealant. You should also pay attention to the efficacy of vapor barrier.

3) Always keep the door closed. Open it only when add wood or start fire.

4) To close the exterior air inlet when the stove is not in use, a damper must be installed in the air intake pipe.

5) Don't forget to open the damper when operate your stove so that the smoke will not enter the house.

6) Always use certified parts for mobile home. Never use a substitute.

The chimney shall be provided with a spark arrester secured to the chimney. The net free area of the arrester above the chimney outlet shall be not less than four times the net area of the chimney outlet, and the vertical height of the arrester above the chimney outlet shall be not less than one-half the diameter of the chimney flue. Openings shall not permit the passage of a sphere having a diameter larger than 1/2 inch (12.7 mm) and shall permit the passage of a sphere having a diameter of 3/8 inch (9.6 mm)

When the space heater is installed in a transportable building, you need to remove the chimney for transportation.

Exterior Kit number: ECPAE

Chimney installation, General steps

Use only approved chimneys, the same size as the output collar, 6 inches in this case. The chimneys used must be tested according to CAN/ULC S629 M87 in Canada and to UL 103 (type HT) in USA. The stove can be installed with a masonry chimney according to ULC S635, ULC S640 and UL 1777. The masonry chimney must be equipped with a stainless-steel sleeve and meet the standards for the masonry chimney with inner sleeve.

Provide a place to sweeping.

It is preferable, if possible, to avoid an outside chimney or built on an exterior wall, and this is even more important for colder areas. Outside chimneys generally have a less efficient draught. They can even have an inverse draught because it is hard to heat them enough so that they can reach their operating temperature. A greater accumulation of creosote, a less efficient draught and a lesser performance are some characteristics of cold chimneys. Draught is proportional to the total chimney height as well as its temperature. It is therefore possible to get a better draught by increasing the chimney's height and by reducing the heat loss with an insulated lining. The chimney has to be installed with a stainless-steel lining. Make sure that all smoke pipe joints are really airtight. A leak reduces the efficiency of the appliance and could even make its utilization dangerous. Using a high temperature silicon or cement to ensure that the smoke pipe joint are airtight. If the chimney pass through the exterior wall or insulated roof be sure the hole after installation needs to be airtightness. Use sealant to make the building airtight.

Note: *This is a general chimneys installation method. Always refer to the manufacturer's manual of the chimney for a more detailed method for your chimney.*

- 1) Determine the total length needed for your chimney.
- 2) Cut the holes into all floor and roof
- 3) If you need to cut a joist, be sure to strengthen the adjacent joists and frame hole respecting the minimum dimensions to be maintained between combustible materials and the firewall. Follow the manufacturer's instructions in the manual supplied with the firestop.
Never cut a structural beam.
- 4) Frame the holes in each level and attic respecting the minimum distance recommended by manufacturer's manual of your chimney. Install firestop in each level.
- 5) Frame the hole into the roof.
- 6) Install the chimney support at the ceiling where stove is installed.
- 7) Stack and lock the factory built chimney section on the support and above the roof.
 - The chimney must be over 36 inches (91.4 cm) over the higher point into the roof opening.
 - The chimney must also be 24 inches over the highest point on the roof inside 10 ft (304 cm) radius around chimney.

- The minimum length of chimney is 12 feet

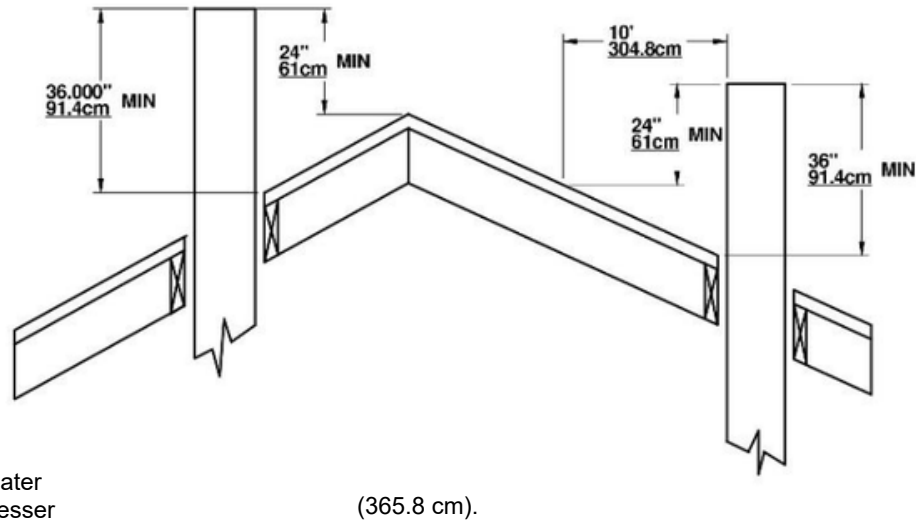

ATTENTION: *Besure the chimney section are locked together and locked onto the chimney support.*

NOTE: *More lengthen chimney than the minimum can add more draft and help to the good working operation of the stove Try the minimum length first then add section if you need more draft.*

- 8) Put the roof flashing over the chimney and seal it with roof caulking.
- 9) Nail roof flashing and reinstall roof covering.
- 10) Slide the storm collar over the chimney and seal it with high temperature caulking.
- 11) Lock the chimney cap and install the spark arrestor if necessary

Note:

- Chimney performance may vary.
- Buildings, trees, roof line and wind conditions affect performance, and can make backflow into the chimney.
- Chimney height may need adjustment if smoking or overdraft occurs.
-

To be installed as a freestanding room heater with clearances in the manufacturer's installation instructions. Not to be installed in a factory-built fireplace.

Inside Masonry Chimney, Vertical Installation

The wood appliance must be installed in accordance with the applicable local laws or the CAN/CSA-B365, NFPA211 (USA) norms. Follow the chimney manufacturer's instructions to install the chimney.

The chimney masonry must have inside a certified metallic sleeve cover up all the chimney height. The sleeve must be at the same diameter of the flue collar; 6 inches (15.2 cm). The junction between sleeve and the chimney connector must be tight and sealed to avoid fume to go indoor.

To pass into a combustible wall between stove and the masonry chimney. The installation method must be safe to prevent fire. Find the last information to your local authority to be sure of the manner you have to.

To install the stove onto an abandoned masonry fireplace and use the good condition masonry chimney the chimney must have inside a certified metallic sleeve cover up all the chimney height. The sleeve must be at the same diameter than the flue collar 6 inches (15.2 cm). The junction between sleeve and the chimney connector must be tight and sealed to avoid fume to go indoor. Don't forget to add a sweep opening.

Outside Vertical Installation

The wood appliance must be installed in accordance with the applicable local laws or the CAN/CSA-B365, NFPA211 (USA) norms. Follow the chimney manufacturer's instructions to install the chimney.

To pass into a combustible wall between stove and the chimney. The installation method have to be safe to prevent fire. Find the last information to your local authority to be sure of the manner you have to. An internal fire stop and an external fire stop must be used.

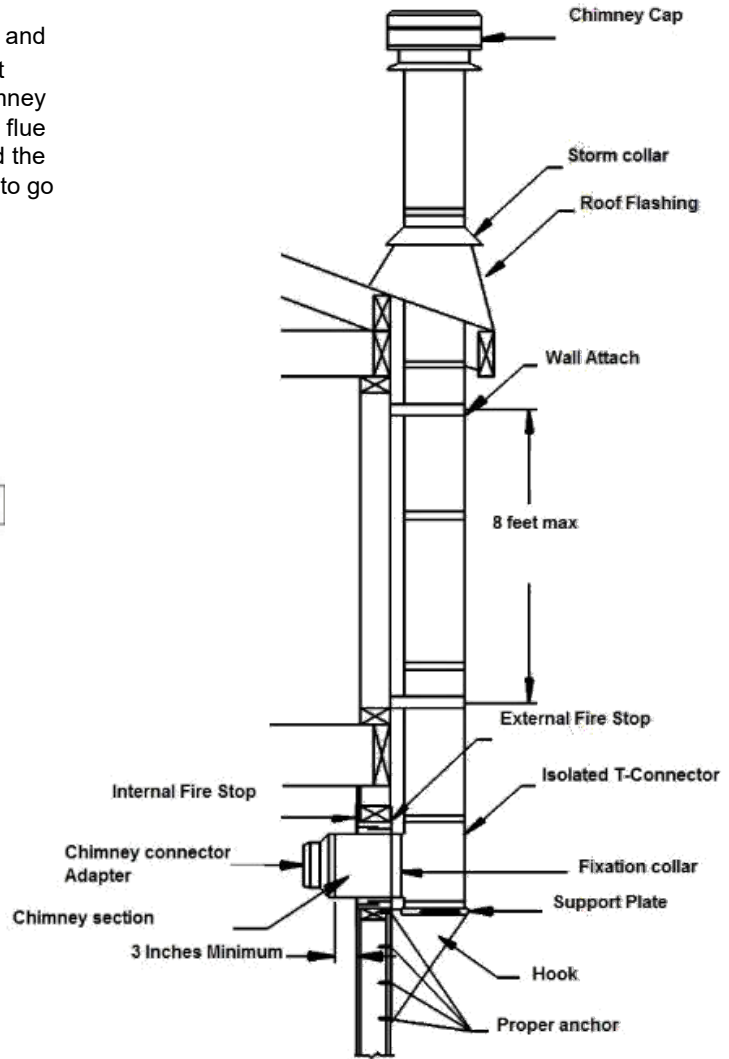
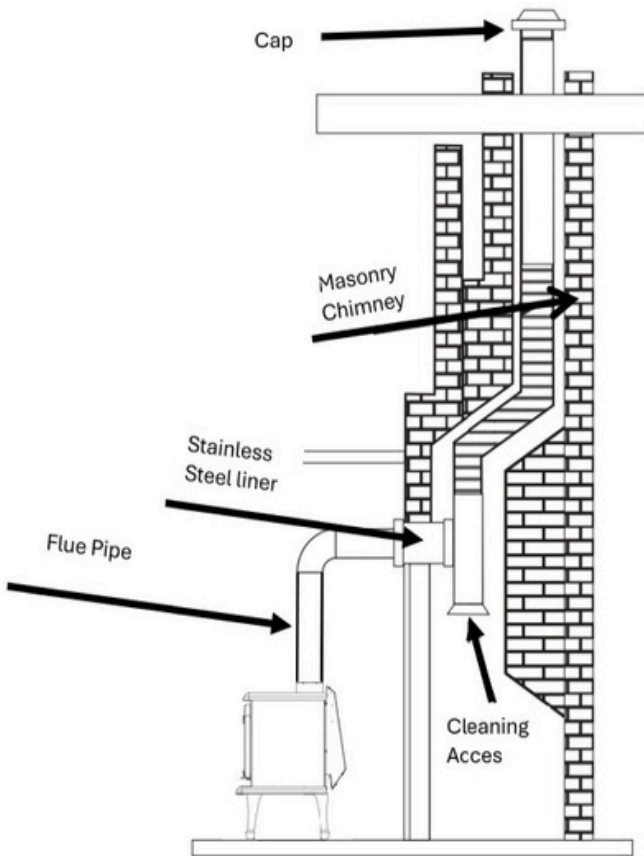

Cathedral Vertical Installation

The wood appliance must be installed in accordance with the applicable local laws or the CAN/CSA-B365, NFPA211 (USA) norms. Follow the chimney manufacturer's instructions to install the chimney.

Always pass chimney between joists. If a joist need to be cut, referring to the National Building code to know how to do it safely to avoid structural integrity fail. Call a carpenter or a certified Installer.

Always frame around chimney. Keep minimal clearances written into your chimney manual.

Do not fill the gap between the fire stop and the chimney.

Nothing must be in contact with the chimney.

Always install a fire stop at each level, in a Floor, in a ceiling, attic and in a Roof.

Always pass with a straight section into a level joist.

The chimney should be support by the cathedral roof. Build a box around it to install ceiling support at its base.

Weight of the chimney never be allow to be support by the stove.

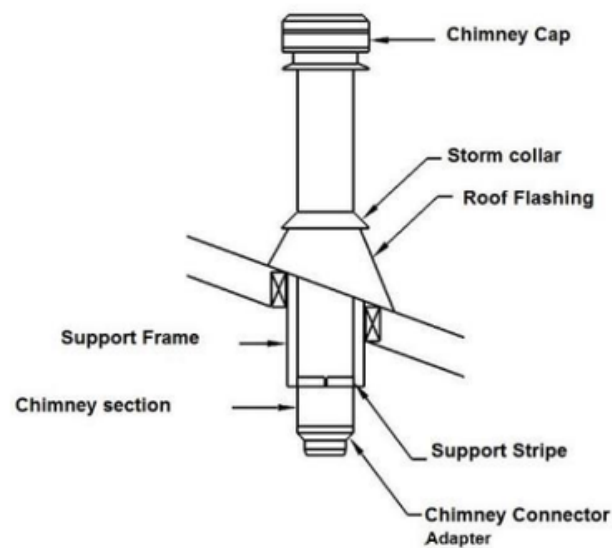

Offset Installation

The wood appliance must be installed in accordance with the applicable local laws or the CAN/CSA-B365, NFPA211 (USA) norms. Follow the chimney manufacturer's instructions to install the chimney.

Always pass chimney between joists. If a joist need to be cut, referring to the National Building code to know how to do it safely to avoid structural integrity fail. Call a carpenter or a certified Installer.

Always frame around chimney. Keep minimal clearances written into your chimney manual.

Do not fill the gap between the fire stop and the chimney. Nothing must be in contact with the chimney.

Always install a fire stop at each level, in a Floor, in a ceiling, attic and in a Roof.

A special fire stop need to be install into the attic. It keep isolation and avoid the attic isolation to be in contact with the chimney.

Always pass with a straight section into a level joist.

Chimney weight have to be support by the lower level with a Ceiling support.

Chimney weight must never be onto the elbows. Install a support band to support the upper straight section over the elbow.

Weight of the chimney never be allow to be support by the stove.

Some restriction have to be respect regarding the maximum angle and length of the offset. See chimney manual for this restriction. Or local building code.

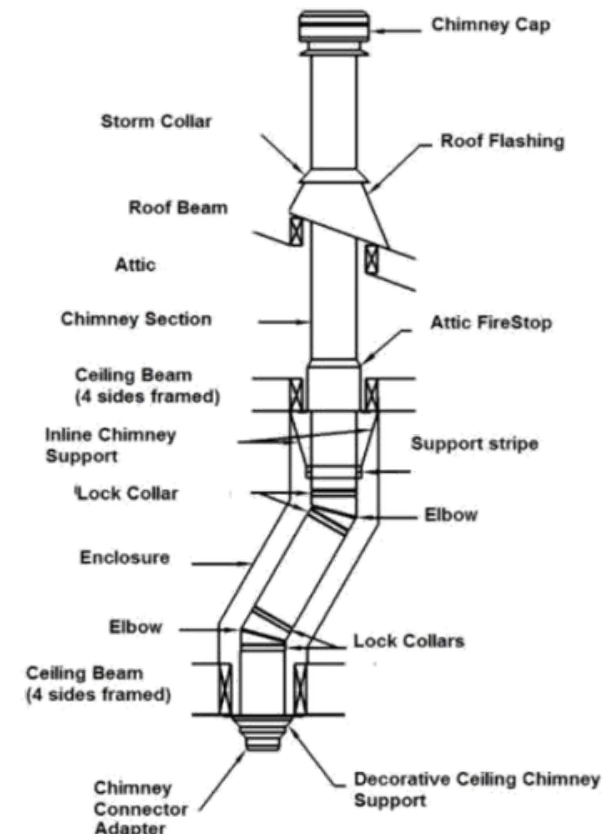

Vertical Installation

The wood appliance must be installed in accordance with the applicable local laws or the CAN/CSA-B365, NFPA211 (USA) norms. Follow the chimney manufacturer's instructions to install the chimney.

Always pass chimney between joists. If a joist need to be cut, referring to the National Building code to know how to do it safely to avoid structural integrity fail. Call a carpenter or a certified Installer.

Always frame around chimney. Keep minimal clearances written into your chimney manual.

Do not fill the gap between the fire stop and the chimney.

Nothing must be in contact with the chimney.

Always install a fire stop at each level, in a Floor, in a ceiling, attic and in a Roof.

A special fire stop need to be install into the attic. It keep

isolation

and avoid the attic isolation to be in contact with the chimney.

Always pass with a straight section into a level joist.

Chimney weight have to be support by the lower level with a Ceiling support.

Weight of the chimney never be allow to be support by the stove.

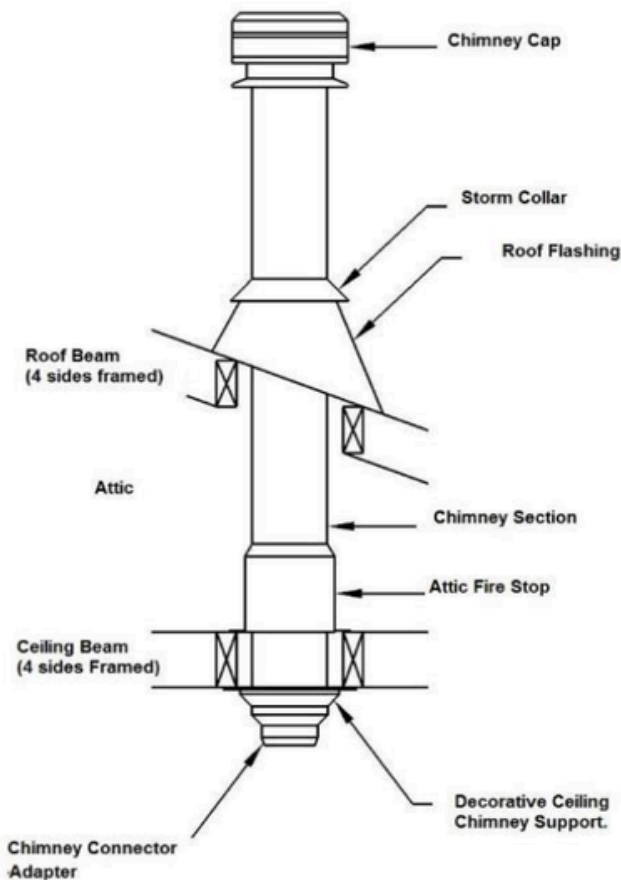
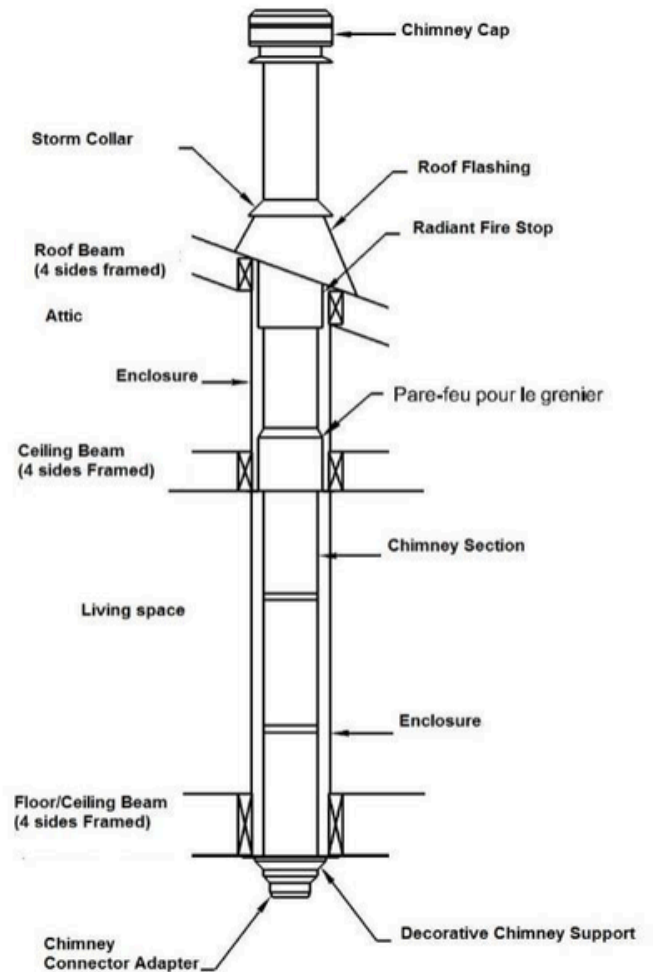

EXTERNAL COMBUSTION AIR SOURCE

In conventional designed house, natural ventilation is enough to operate the wood stove.

In some new energy saving house, natural ventilation is not enough to good operation of your stove. To avoid reverse circulation of smoke caused by negative pressure when turning on some fan such as bathroom fan, cooking fan or a dryer, it is recommended to install the external combustion air inlet.

Without the external air inlet, open a window slightly in the room where the appliance is placed in order to avoid the negative pressure caused by the appliances mentioned above.

A mobile home on a foundation is considered as a conventional house.

Exterior Air Intake pipe

This appliance is certified for the mobile home installation. An external air intake is necessary.

We recommend using a 4 inches (10.7 cm) aluminum flexible pipe with a dumper outside air inlet equipped with grate.

Other pipe material must be complied with ULC-S110 norms or UL-181 Class1 norms, equipped with thermal resistant isolation and must be corrosion resistant.

The stove must be fix to the structure when an exterior air intake is installed.

Installation of Air Intake Pipe

- 1) To install the exterior air intake pipe, find the hole under the stove back and fold the 3 tabs outside the Intake box. Insert the pipe into the hole and screw the pipe using the 3 holes in the tabs. Put a generous layer of high temperature latex caulking onto the joint to ensure the pipe is sealed.
- 2) Cut the exterior wall and install Air Inlet kit following the manufacturer installation instructions. Be sure to seal it correctly to preserve the vapour barrier of your house.

3) Install a small rigid section inside the house and put a damper to close the air Inlet. This damper is to reduce the cold air circulation into the stove when it is not in service.

4) Plug the flexible air inlet pipe onto the damper section. 5) Put a thermal resistant isolation onto the pipe if the pipe is not isolated.

To avoid that the cold air doesn't come in the stove, we recommend installing a valve which closes the pipe near the outdoor air inlet.

Air Inlet Obstruction

If the stove extinguishes after closing the door, it's possible that the air inlet is obstructed by something.

After a long unused period, insects or animals can build a nest inside the air inlet.

After a storm in winter, snow can accumulate over the air inlet and obstruct it.

Before warming season, always inspect air inlet pipe to be sure nothing is obstructing the outside air inlet.

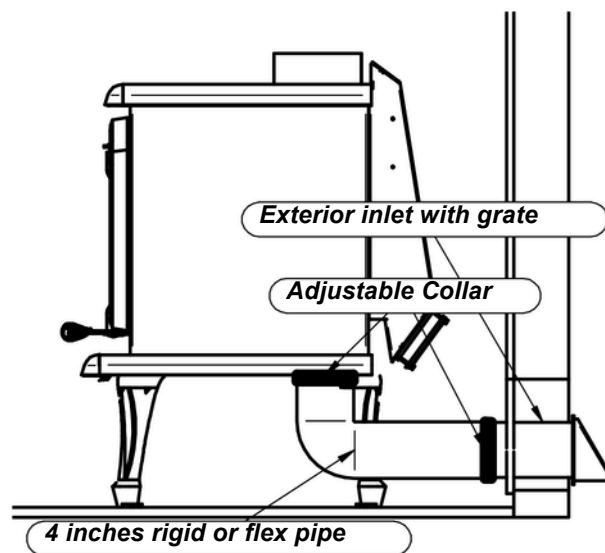

STAINLESS STEEL TUBES REPLACEMENT

Although the tubes are in stainless steel, with extreme temperature and conditions, the tubes are eventually corroded and perforated by normal deterioration. They must be replaced by a new one to ensure the performance of your stove.

Stainless steel tubes Installation

There are three types of tubes used into the stove. Two of them are single-side perforated (1) and are in the back of the heat chamber.

The 3rd tube from the back (2) is also single-side perforated, but it is larger than other single-side perforated tubes (1).

The front heat chamber is covered by a double-side perforated tube (3).

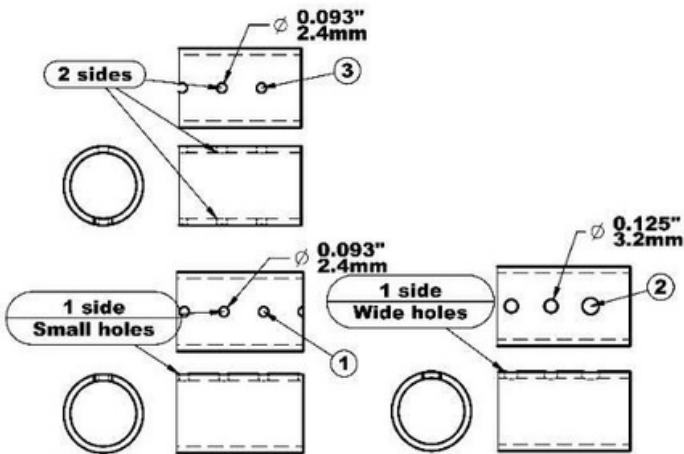
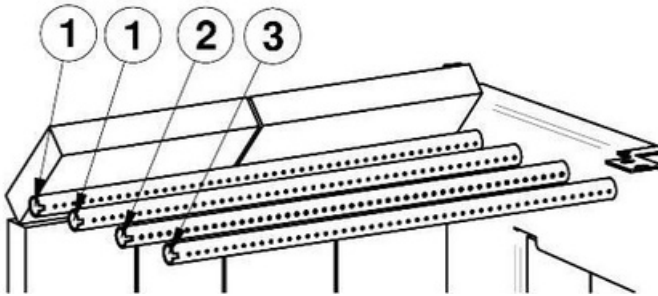

How to install tubes

- 1) Insert the tube into the round hole in the hot air corridor.
- 2) Insert the other side in the corresponding hole of the hot air corridor.
- 3) Align holes and put the screw on both sides to hold the tube.

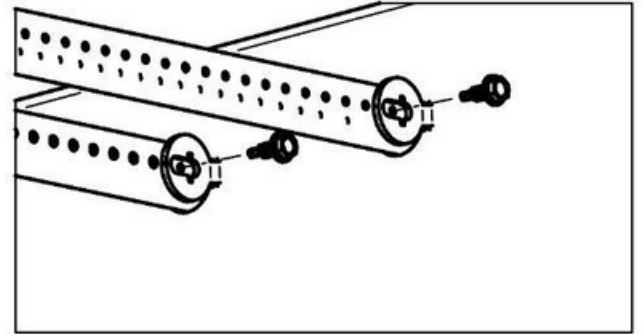

- 4) Install the next tube.

To remove tubes, do these steps in reverse order.

OPERATING INSTRUCTIONS

OPERATE ONLY WHEN DOOR IS CLOSED: Keeping the door open might over fire and cause permanent damage to the stove or a chimney fire.

➤

IT'S RECOMMENDED TO INSTALL A CO, CO2 AND SMOKE DETECTOR INTO THE SAME ROOM THAN THE STOVE. The smoke detector might go on when there is smoke leaking out.

➤ **NEVER SLAP THE DOOR.**

➤ **NEVER BURN INFLAMMABLE LIQUID: Inflammable liquid makes very intense heat and it is hard to control the combustion. It might cause the runaway and overheat of stove. This can consequently make permanent damage to the stove or a chimney fire.**

➤ **ALWAYS VERIFY IF THE AIR INLET IS NOT OBSTRUCTED BEFORE LIGHTNING A FIRE.**

➤ **NEVER ELEVATE FIRE WITH GRATE OR ANDIRON. ALWAYS MAKE FIRE DIRECTLY IN THE HEARTH.**

Burn rate category

Category 4 – maximum

- Preburn the wood stove with 3 or 4 lbs of kindling
- Burn same preload weight as the load
- In the midrange of the allowable load range, insert load (approximately 2.5 lbs)
- Keep door slightly open to help the ignition of the load for approximately 2 minutes
- Keep the air fully open

Category 3 – Medium

- Preburn the wood stove with 3 or 4 lbs of kindling
- Burn same preload weight as the load
- Set the inlet at midpoint when 6.5 lbs left
- In the midrange of the allowable load range, insert load (approximately 2.5 lbs)
- Keep the door slightly open to help the ignition of the load for approximately 2 minutes
- Keep the primary air inlet fully open for the first 4 minutes following the insertion of the load
- Following the first 4 minutes, close the inlet to the midpoint

Category 2 – Medium-Minimum

- Preburn the wood stove with 3 or 4 lbs of kindling
- Burn same preload weight as the load
- Set the inlet at midpoint when 6 lbs left
- In the midrange of the allowable load range, insert load (approximately 2.5 lbs)
- Keep the door slightly open to help the ignition of the load for approximately 2 minutes
- Keep the primary air inlet fully open for the first 4 minutes following the insertion of the load
- Following the first 4 minutes, close the inlet to the midpoint

- At 5 minutes following the load insertion fully close the air inlet

Category 1 – Minimum

- Preburn the wood stove with 3 or 4 lbs of kindling
- Burn same preload weight as the load
- Set the inlet at midpoint when 6 lbs left
- In the midrange of the allowable load range, insert load (approximately 2.5 lbs)
- Keep the door slightly open to help the ignition of the load for approximately 2 minutes
- Keep the primary air inlet fully open for the first 4 minutes following the insertion of the load
- Following the first 4 minutes, close the inlet to the midpoint
- At 5 minutes following the load insertion fully close the air inlet

Primary and secondary air admission control

When the handle under the front tablet of the stove is pushed completely backward, the air admission is only from the tube. This is what we called "Secondary air admission". On the other hand, when the handle is pulled fully forward, the air admission is directly from the top of the door opening and this is what we called "Primary air Admission".

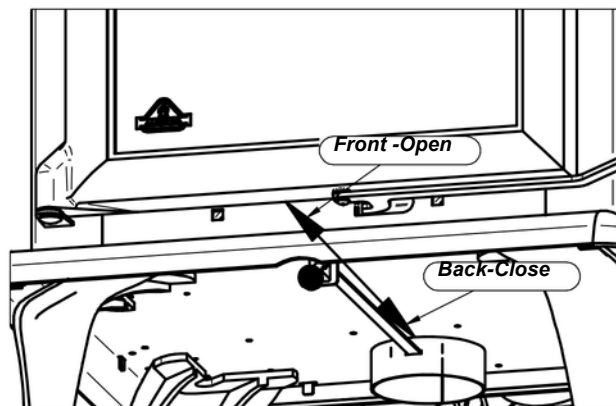

Warning: Operating your stove with the Primary air admission fully open for a long period of time can damage the stove.

IT IS PROHIBITED TO MODIFY AIR ADMISSION TO OBTAIN A BRIGHT FIRE OR FOR ANY OTHER REASON. MODIFICATION CAN VOID GUARANTEE.

Lightning fire

After installing correctly the stove following the instruction of the manufacturer, you are ready to light it.

- 1) Pull the control knob forward to let the direct air admission in the combustion chamber.
- 2) Put paper and kindling wood into the combustion chamber and light the fire in your preferred way.
- 3) Close the door partially keeping a slight opening. When chimney has been hot enough, close completely the

door and let the air admission in the horizontal position so that your fire is kindled.

- 4) Once you have a glowing ember, it's time to add logs. Follow now the instruction section on how to keep a fire.

DO NOT OVER CHARGE THE STOVE OVER THE UPPER BRICK.

You can control the combustion by turning up or down the handle. The wood will burn more rapidly when more primary air is set. Otherwise, the wood burn more slowly and more efficiently with the handle set to secondary air.

➤

OPERATE STOVE WITH THE PRIMARY AIR ADMISSION FULLY OPEN FOR A LONG PERIOD OF TIME, CAN DAMAGE THE STOVE BY OVER FIRING.

➤ **NEVER LEAVE THE STOVE UNATTENDED WHEN THE DOOR IS SLIGHTLY OPEN. ALWAYS CLOSE THE DOOR AFTER LIGHTNING.**

➤ **USE THE STOVE ALWAYS LEAVING THE DOOR CLOSED.**

NEVER

➤ **OR USE CHEMICAL PRODUCTS INFLAMMABLE LIQUID TO START THE FIRE OR REVIVE THE FLAME.**

➤ **DO NOT BURN TRASH OR ANY OTHER INFLAMMABLE PRODUCT SUCH AS GAZOLINE, NAPHTHA OR MOTOR OIL.**

➤ **DO NOT BUILD FIRE NEAR THE DOOR GLASS.**

➤ **KEEP THE INFLAMMABLE PRODUCTS AWAY FROM THE APPLIANCE.**

➤ **DO NOT BURN : GARBAGE, LAWN CLIPPING, YARD WASTE, MATERIAL CONTAINING RUBBER including tires, WASTE PETROLIUM PRODUCTS, PAINTS, PAINT THINNERS, or ASPHALT PRODUCTS, MATERIALS CONTAINING ASBESTOS, CONSTRUCTION or DEMOLITION DEBRIS, RAILROAD TIES , PRESSURE-TREATED WOOD, MANURE, ANIMAL REMAINS, SALT WATER DRIFTWOOD, UNSEASONED WOOD,**

➤ **PAPER, PARTICLES, BOARD BOARD.** Prohibition against burning these materials does not prohibit the use of fire starters made from paper, cardboard, saw dust, wax and similar substances for the purpose of starting a fire in an affected wood heater

➤ **BURNING THESE MATERIALS MAY RESULT IN RELEASE OF TOXIC FUMES OR RENDER THE HEATER INEFFECTIVE AND CAUSE SMOKE.**

First fire

During the first hours of operation, you must heat it gradually. In order to allow an appropriate baking of the paint and facilitate its adhesion with metal, do not heat the appliance with a strong fire. It will also avoid thermal shock which could lift up the paint or fade the color.

Make sure that the room is ventilated enough in order to eliminate the odours and the smoke coming from the paint during the first hours of use.

Even if this nuisance is temporary, open the windows and the doors in order to ensure a good ventilation. This special paint is conceived to tolerate temperatures until 1200°F (650°C).

Keep a fire

To add wood into the stove and keep a fire:

- 1) Pull the control knob forward and wait a few second to let the fire adjust to the new conditions.
- 2) Open the door handle to the first position and wait for a while until the fire has been adjusted.
- 3) Turn the door handle completely and leave the door half-open and let the fire set up.
- 4) Open the door completely.
- 5) Move embers near the door with poker to supply it with oxygen and make it burn completely.
- 6) Add firewood over the ember, keeping it away from the glass door to avoid flame touching the ceramic glass.

ATTENTION:

- **DO NOT OVER CHARGE THE STOVE OVER THE UPPER BRICK.**
- **DO NOT BUILD A FIRE NEAR THE WINDOW.**
- **THIS APPLIANCE IS DESIGNED TO BURN DRY CORDWOOD. WE DON'T RECOMMEND ANY OTHER TYPE OF WOOD.**

- 7) Close the door slightly and let the wood burn.
- 8) Once the fire gets stable, close and lock the door.
- 9) Push the air admission knob to needed setting.

NEVER LEAVE THE STOVE UNATTENDED WHEN THE DOOR IS SLIGHTLY OPEN. ALWAYS CLOSE THE DOOR AFTER ADDING A LOAD. Keeping the door open is not advised. When the appliance is heated, sparks may come out of the hearth. A fire runaway may be created causing the appliance and flue pipes to overheat.

DO NOT USE ANY INFLAMMABLE LIQUID TO REKINDLE THE FIRE.

Fan Control

When it's ON, the snap disc will start at the moment when the temperature of ventilation box gets 120 Fahrenheit (49 ° Celsius).

In OFF Position, the fan is turned off and it doesn't start.

NEVER ROUTE THE ELECTRIC WIRE OF FANS IN FRONT OR UNDER APPLIANCE.

Fuel Selection

This heater is designed to burn only firewood. Using firewood dried properly results in higher efficiencies and lower emissions of pollutant compared with using softwood or fresh wood.

Moisture Meter Information

Firewood is ready to use at 10-25% moisture content.

Fresh cut logs can have a moisture content of 80% or more, depending on species. During the drying process, wood might shrink, split, twist or change shape. In general, wood must be dried before use. Air drying, i.e. 'seasoning' is the most common method used for cordwood.

Season wood outdoors through the summer for at least 6 months before burning it. Properly seasoned wood is darker, has cracks at the ends, and sounds hollow when smacked against another piece of wood.

In most parts in the North America, the minimum moisture content that can be generally obtained in air drying is about 12 to 15 percent.

Efficiency

The average of the efficiency of the stove is 72.9%. When the seasoned wood has lower moisture, the efficiency will be better. When the outside temperature is really cold, it is important to create a good draft in chimney. When the appliance is in the basement, the chimney is higher than if the appliance would be in the main living area. The draft will be better because we have more length of chimney.

Things not to burn

Never use gasoline, gasoline-type lantern fuel, kerosene, charcoal lighter fluid, or similar liquids to start or 'freshen up' a fire in this heater. Keep all such liquids well away from the heater while it is in use.

- Garbage
- Lawn clippings or yard waste
- Materials containing rubber, including tires
- Materials containing plastic
- Waste containing petroleum products, paints or paint thinners, or asphalt products
- Materials containing asbestos
- Construction or demolition debris
- Railroad ties or pressure-treated wood
- Manure or animal remains

- Salt water driftwood or other previously salt water saturated materials;
- Unseasoned wood
- Paper products, cardboard, plywood, or particleboard.

The prohibition against burning these materials does not prohibit the use of fire starters made from paper, cardboard, saw dust, wax and similar substances for the purpose of starting a fire in

Burning these materials may result in release of toxic fumes or render the heater ineffective and cause smoke.

Wood storage

The cordwood must be stored into dry place, away from bad weather.

It should not be stored under or near the stove.

If any wood is stored next to the stove, it must respect the minimum clearances to avoid self-ignition temperature.

- 10 inches (25.4 cm) behind
- 20 inches (50.8 cm) beside
- 48 inches (122 cm) in front

Draft

Draft is the force which moves air from the appliance up through the chimney. The amount of draft in your chimney depends on its length, local geography, nearby obstructions and other factors. Too much draft may cause excessive temperatures in the appliance and may damage the appliance.

An uncontrollable burn or excessive temperature indicates excessive draft.

Insufficient draft will cause the appliance to leak smoke into the room through appliance and chimney connector joints.

MAINTENANCE

Ash Removal

The wood burning doesn't transform the wood into combustion gas completely. It makes some residue called ash and it must be removed from the combustion chamber to help oxygen circulation.

The ash have to be removed periodically every 2 or 3 days

excessive heavy warming period. Never had accumulation into the combustion chamber because it can reduce performances of your stove by diminish the air circulation between logs.

When ashes get 3 to 4 inches deep in your firebox, and when the fire has burn down and cooled, remove excess ashes. Leave an ash bed approximately 1 inch deep on the firebox bottom to help maintain a hot charcoal bed.

The best time to remove ash is after a long warming period like morning when the stove is relatively cold enough to manipulate ash and the chimney is still hot. The hot chimney draft will vacuum the dust inside the stove.

To clean ash from the combustion chamber, you must have the following tool.

- Ash shovel
- Ash brush
- A metal bucket with airtight lid.

Some embers is mix with ash and still lit a few hours or a few days. It is very important that the metal lid was airtight. The bucket must be put on a non-combustible tile or brick.

Ash Disposal

Some embers mixed with ash can still be lit. If embers have enough oxygen, they can still stay lit some hours and even a few days.

It's mandatory to store ash pending disposal:

- Into a metal container with an airtight metal lid correctly closed
- Outside the house on a non-combustible material such as gravels, concrete and bricks.
- Far enough any combustibile material.
- Far enough any inflammable liquid and vapor.

If the ashare disposed of by burial in soil or otherwise locally dispersed,they should be retained in the closed container until all cindershave thoroughly cooled.

NEVER PUT TRASH INTO THE ASH CONTAINER.

Creosote Formation

When wood is burning slowly, it produces tar and other organic vapors, which are combined with expelled moisture to form creosote. The creosote vapor condenses in the relatively cool chimney flue of a slow-burning fire. As a result, creosote residue accumulates on the flue lining and this creosote makes an

extremely hot fire whenignited.

The chimney connector and chimney should be inspected at least once a week during the first month to determine if a creosote buildup has occurred and to see how often you have to sweep it. Warmer your fire is, less creosote buildup occurs.

Contact your local fire authority to know how to handle a chimney fire.

Chimney Inspection

Wood moisture, a type of wood, the combustion quality are the factors that can influence creosote buildup speed into the chimney and chimney connector.

The chimney and the chimney connector must be inspected at least one every two months during the warming season or more depending on your installation. You can call a Chimney sweeper to evaluate the creosote formation or you can do it yourself. Extinguish the wood stove, wait for cool down then unscrew the chimney connector and inspect the chimney connector and the factory build chimney with a spot light to see if a creosote buildup as occurred. For a masonry chimney, insert a mirror in the cleanout opening at the bottom on a bright day. For an outdoor factory build chimney, open the cap at the bottom of chimney.

If there is 1/8 inches (3 mm) or more creosote buildup, smaller apparent diameter or if you cannot see the chimney cap, it's a sign to sweep your chimney connector and your chimney to remove creosote.

Chimney Sweeping

Chimney Sweeping needs a special tool such as fiberglass rod, an adapted diameter brush and a rope.

Sweeping chimney also requires to climb on the roof to remove the chimney cap and sometime even a very high chimney section too.

We recommend to call a Professional chimney Sweeper certified by APC in Quebec, the WETT in the rest of Canada or by NFI in United States.

Door maintenance

The door is the mobile element that needs a special attention. Its tightness is essential. One of the first signs of wear braided fiberglass rope is the white soot sticking on the glass where the air leaks.

Air tight Adjustment

If the braided fiberglass rope still seems good enough but little flattened, it needs probably to be tightened.

Door adjustment (right side)

This side adjustment can be done with the screw under the door near the hook hole.

- 1) Unlock and open the door.
- 2) With a square screwdriver, turn clockwise the adjustment screw a quarter turn.
- 3) Put a piece of paper between the frontage of stove and braided fiberglass rope. Close and lock the door.
- 4) If the paper slides easily when you pull it, repeat steps 1 to 3 again.
- 5) If the screws are tightened but the piece of paper comes off easily, the braided fiberglass rope must be changed.

Cleaning up glass

To clean the glasses, J.A. Roby Inc. recommends using products sold for this purpose or an oven cleaner avoiding touching paint part.

Avoid cleaning with abrasives and cleaning the hot glass.

Cleaning hot glass can cause a thermal shock and can break the glass.

Uninstalling and installing door

Do not unscrew the lower hinge when disassemble the door.

- 1) Keep the door locked.
- 2) Loosen the upper hinge without removing the nut.
- 3) Unlock the door and open it while holding it.
- 4) Tilt the door slowly downward to remove the upper hinge
- 5) Lift the door and remove the lower hinge.

Installing the door :

- 1) Insert the bottom hinge and bring up the door. Place the nail in the upper hinge.
- 2) Close the door by leaning it against the facade then level the door.
- 3) Close and lock the door, then make sure the door is placed horizontally.
- 4) Tighten the upper hinge and align the washer with the hinge support.
- 5) Make sure everything is air tight.

Replacing broken glass

WARNING: NEVER OPERATE STOVE WHEN THE GLASS IS BROKEN OR CRACKED.

DO NOT SLAP THE DOOR.

NEVER BUILD FIRE NEAR THE GLASS.

NEVER PUT WATER ONTO THE GLASS TO AVOID A THERMAL SHOCK.

Replace only with a 4mm ceramic glass with the right shape.

DO NOT USE SUBSTITUTE.

Steps to replace broken glass

- 1) Loosen partially the screws retaining the four glass supports.
- 2) Remove the broken glass and all pieces of broken glass and clean the door.

There is a fiberglass rope for sealing. If not, you need to install it. Stick the flat fiberglass rope around the glass without pulling it excessively. A sticking side is already on the flat rope.

Install the new glass and put the lower support first and gently tighten screw. If screws are tightened too much, it makes pressure points and it might break the glass when it gets hot.

Install the top support and gently tighten screw.

Verify if all the screws are tightened properly.

If you cannot replace glass with the door in place, you may have to remove the door. To do so, follow the instruction of this manual.

Fiberglass rope replacement

When it is impossible to adjust the door because of the flattened fiberglass rope, it is the time to change it. If the rope is damaged, you also have to replace it.

Use a ½ inches (12.7mm) braided fiberglass rope.

To install the new fiberglass rope, we recommend to detach the door from the stove. Please see the pertinent section in this manual.

Fiberglass rope preparation

- 1) Take the end of the fiberglass rope and push fiber inside.
- 2) Add little touch of high temperature latex inside the end of the fiber glass rope to make a clean end.
- 3) Remove old fiberglass rope and clean the groove.
- 4) Starting at the lower corner near the hinge put the fiberglass rope into the groove without giving any tension to verify the length of the rope.
- 5) Cut the rope in more than ½ inches and repeat the step 1 and 2.

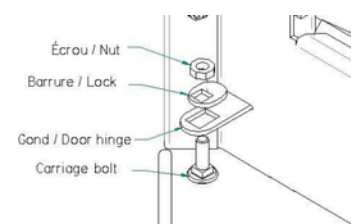

Fiberglass rope installation

- 1) Put a high temperature latex inside the clean groove to glue the fiberglass rope.
- 2) Starting at the lower corner near the hinge put fiberglass rope into the groove without giving any tension
- 3) Align the two fiberglass rope ends perpendicularly and put some high temperature latex in between.
- 4) Let dry the high temperature latex for at least 48 hours. Put the door back on the hinge and readjust the tightness.

WHAT TO DO IN CASE OF CHIMNEY FIRE

CONTACT YOUR LOCAL AUTHORITY TO KNOW WHAT TO DO IN CASE OF CHIMNEY FIRE. AND BE SURE TO KNOW PROCEDURE IN CASE OF CHIMNEY FIRE.

1. Close all door, the air inlet and the damper.
2. Water the combustible materials around the stove.
3. Trigger alarm and leave the house, if necessary, and call the Fire department.
4. Never touch the chimney while is burning.

Do not use the chimney before an inspection or repair necessary.

ANNEX 1

Exploded diagram of door

Arch door

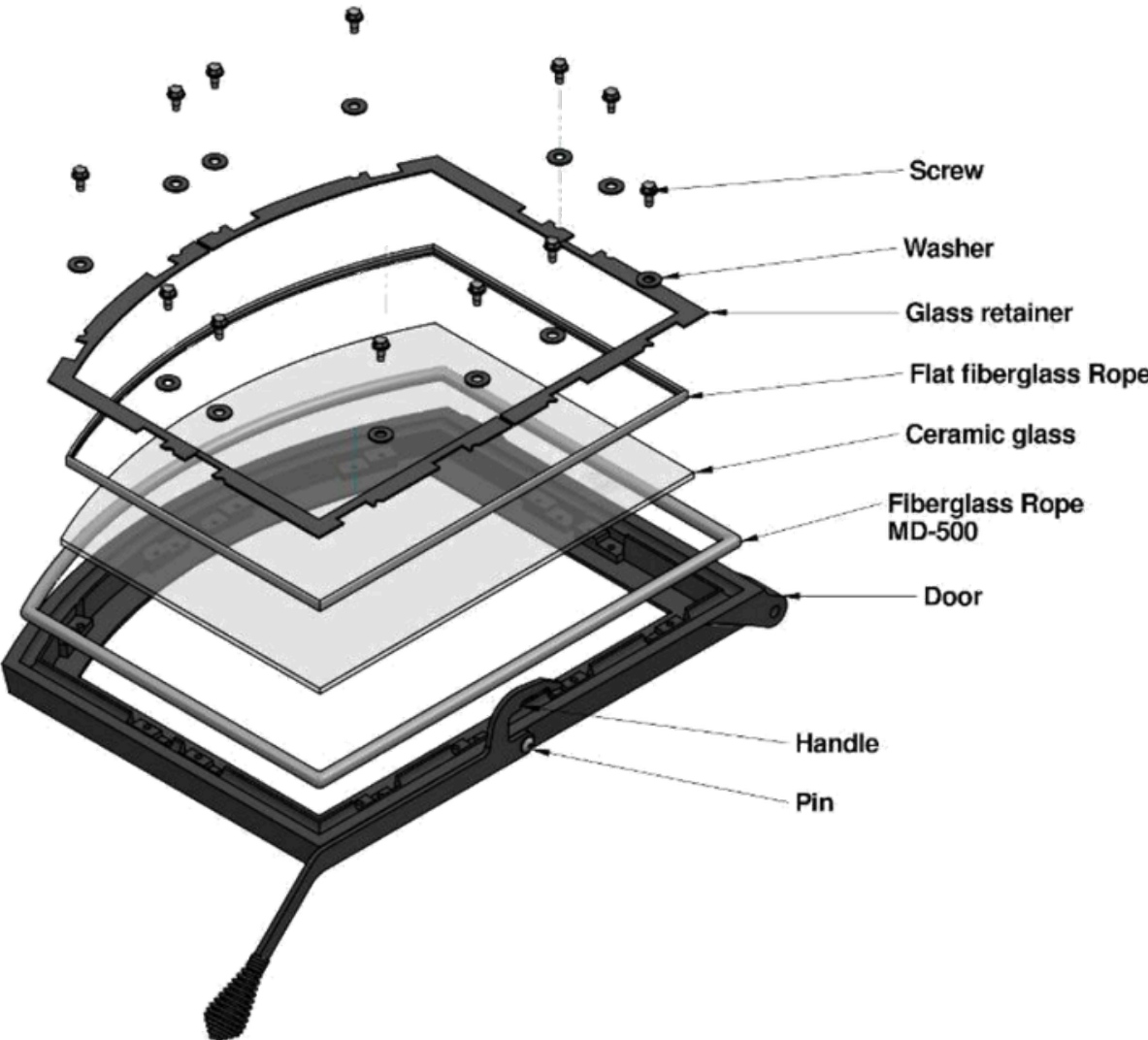

ANNEX 2

Fanselectric wiring diagram

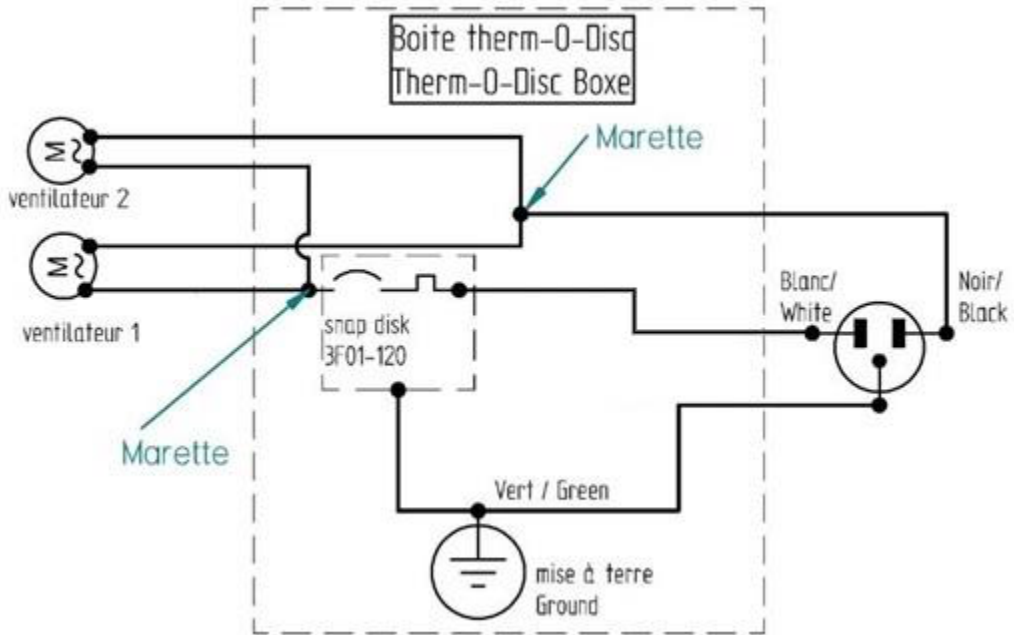

Snap disc box parts description

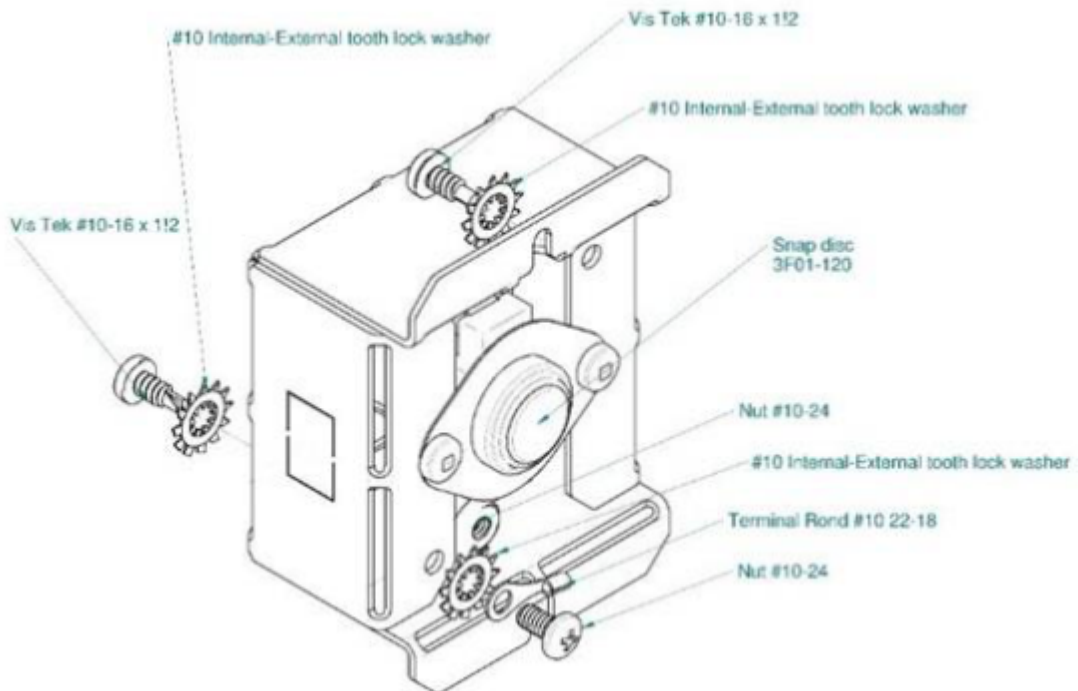

ANNEX 3

Partsthatcan be replaced

- Bricks
- Door glass
- Spring Handle
- Stove Door with handle
- Fans
- Flat fiber glass rope (around glass)
- Round fiberglass rope
- Ash Plug
- Slotted Brick Washer

Call your stove seller representative to order parts.

ANNEXE 4

Pedestalinstallation

The pedestal consists of 5 components.

- 1) Left Side
- 2) Right Side
- 3) Reinforcing plate
- 4) Base
- 5) screws

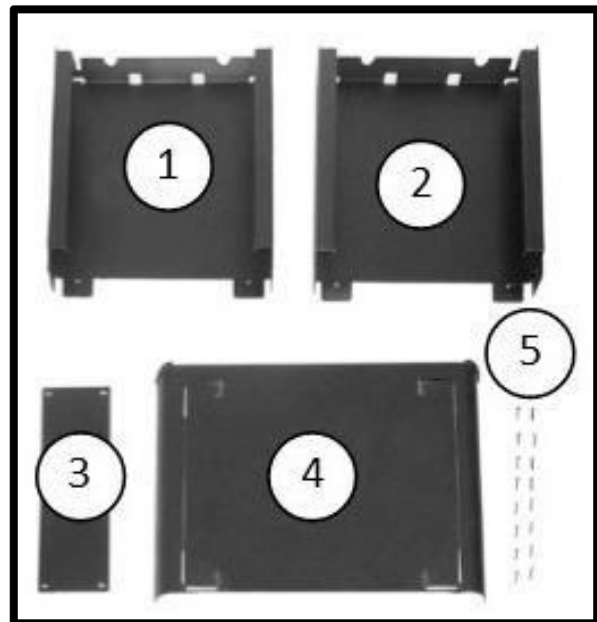

1. Detach stove from the skids.

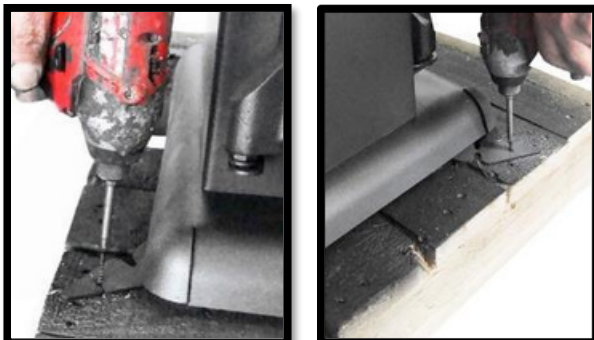

2. Put the stove on its back.



3. Detach skid anchor. We recommend you to ask for help to avoid accident. Be careful not to injure yourself.



5. When you insert the left side part, several sections for fixing will be sticking out through the base part. Place screws in the holes of these sections.



4. Insert the left side part on the base.

Note : To distinguish the left side part from the right side part, find the holes for the reinforcing plate on the non-rounded side of the base part, at the back of the pedestal.

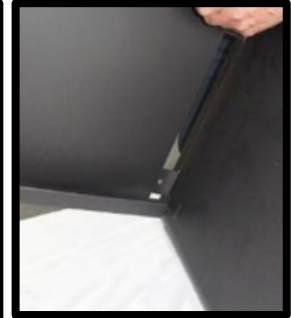
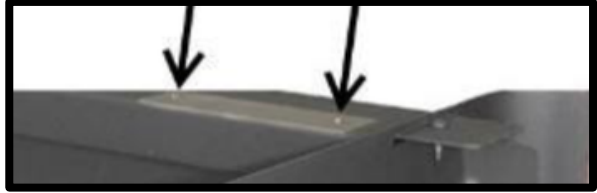

6. Install the right side part. Make sure that the sections for fixing the reinforcing plate is on the back of the pedestal.



7. Remove the screws for the ashtray holder.



8. Install the ashtray holder by screwing with the holes for this purpose.



9. Open the pedestal slightly and tack the washers on both sides. Attach it with nuts.



10. Install the reinforcing part at the back of pedestal. Let the stove stand on the pedestal.

